

# Tekmar<sup>®</sup>

## LSC 2000 QUICK START GUIDE

This concise guide is intended to enable an operator who is already familiar with purge and trap systems to quickly understand and operate an LSC 2000. Detailed explanations of all operations can be found in the complete user manual.

**NOTE:** A blank trap tube is installed in all new LSC 2000s. Replace the blank trap with a packed trap before running samples.

### **POWER UP**

When first powered up the LSC 2000 performs a series of self tests. These tests take approximately a minute. Tests may be skipped by pressing F4 (Skip). If the sample heater or capillary interface modules are not installed, the tests for them **MUST** be skipped manually. When the self tests are complete, the Configuration screen appears. Enter the current date and time by pressing F2 (Clock). Installed accessory modules can be turned on and off by pressing F3 (Inst.). The unit now goes to the Start Up mode for Method 1.

### **METHODS**

Up to four methods can be stored in the memory of the LSC 2000. When powered up, the unit automatically goes to Method 1. (The default values for Method 1 are those specified in the EPA's Method 601.) To go to another Method or to modify the parameter values for a Method, press F1 (Meth). The system asks which Method (1-4) you wish to use. Press the appropriate digit on the keypad. If you wish to run this method, press F2 (Run). If you wish to view or change parameter values, press F3 (Edit).

**NOTE:** If this is the initial power up or if this is a power up after a power failure that resulted in memory loss, the "Parameters Invalid" screen will appear, indicating that the system is loading the parameter default values into Random Access Memory (RAM). Press F4 (Exit) to leave the "Parameters Invalid" screen.

If you pressed F2 (Run), the system will go to Start Up mode in the Method you chose. If you pressed F3 (Edit), the system will go to the parameter listing for the Method you chose. To move the cursor use F3 (->) or <- (Backspace). To view the next section of the parameters listing (there are 5 "pages"), press PAGE DOWN. To change a parameter value, move the cursor the desired parameter and press ENTER. Press the

appropriate digits to input the new value and press ENTER again. To leave the Method Parameters Listing, press F4 (Exit).

#### **AUTOMATIC OPERATION**

When all of the temperature zones have stabilized the LSC 2000 goes to Standby mode. Press AUTO to cause the unit to run automatically. An LED will light up, confirming automatic status. When all of the applicable parameter values have been met, the unit proceeds to Purge Ready mode. Here, the LSC 2000 is ready to purge the sample. Inject the sample through the sample valve and press START. Purge, Prepurge, or Preheat (as applicable) will begin immediately. The unit then proceeds through all the steps in the program. If a GC interface is not installed, the unit will stop at Desorb Ready. Press STEP to advance the unit to Desorb Preheat. To pause operation during the program, press HOLD. To resume operations, press AUTO. Press STEP to advance from one mode to the following mode.

#### **Viewing Angle Adjustment**

The viewing angle of the LCD screen can be adjusted to optimize readability in a variety of unit setup conditions. Press PAGE UP to increase the angle of the screen and PAGE DOWN to decrease the angle. Press the key down firmly for a continuous change in the angle or press and release the key for an incremental change.

**NOTE:** The viewing angle cannot be adjusted while the unit is in a mode where PAGE UP and PAGE DOWN provide other functions (for example, while editing the Method Parameters Listing).

#### **STEP TO STANDBY**

This key functions as an abort command, cancelling any run in progress and returning it to Standby mode. Since this key cancels a run, it must be pressed again to confirm. This sequence avoids the possibility of stopping a run due to an inadvertent keystroke.

#### **STEP TO BAKE**

This key causes the unit to go directly to Bake mode, bypassing all intermediate modes. Step To Bake is mostly used to condition traps.

#### **DRAIN**

This key activates the sampler drain mechanism. When the drain is open, a flashing "D" will appear on the screen between F3 and F4. Press DRAIN again to close the drain.

Tekmar Company • P.O. Box 371856 • Cincinnati, Ohio 45222-1856  
(800) 543-4461, or in Ohio, (800) 344-8569

*LSC 2000*  
*INSTRUCTION MANUAL*

---

---

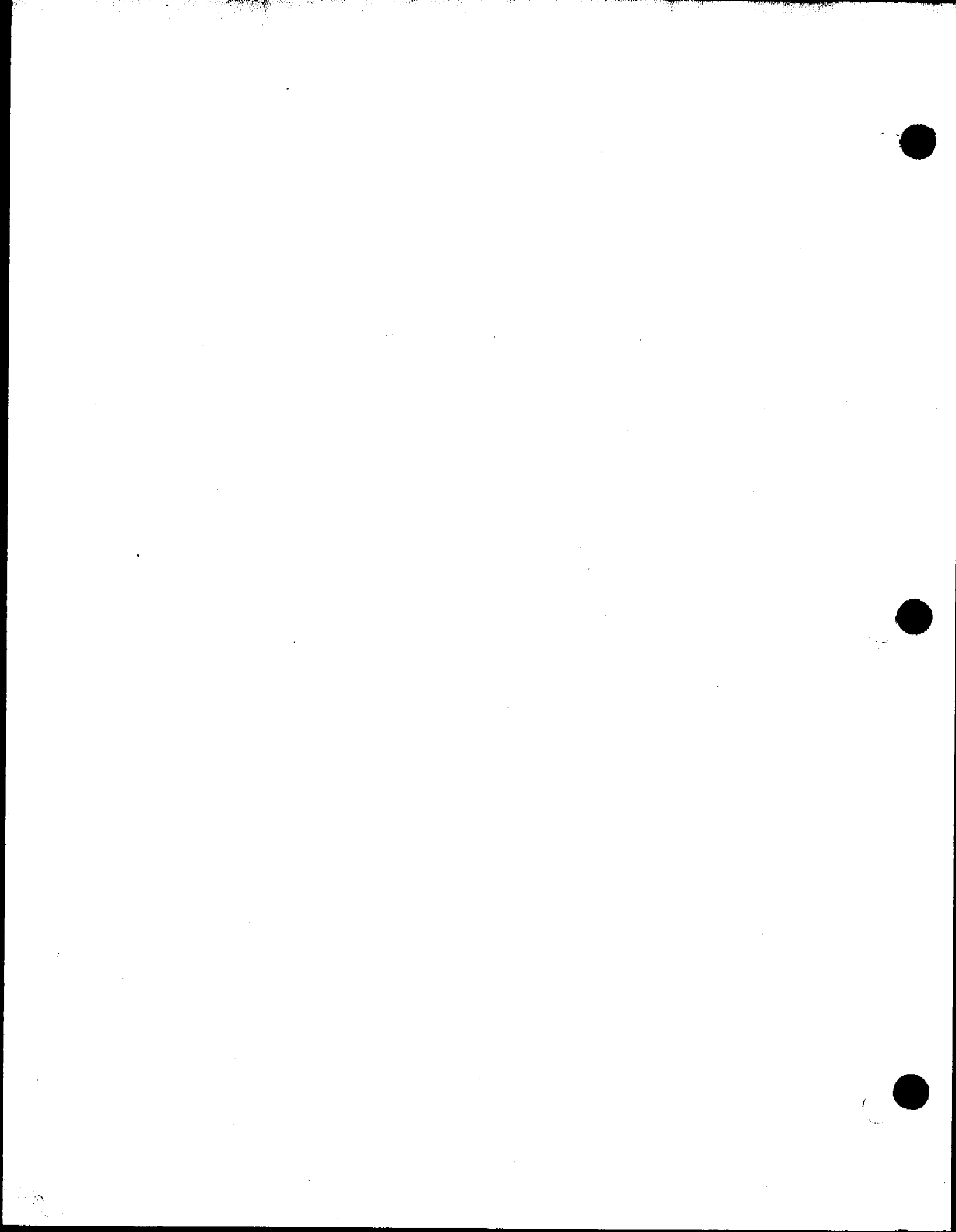

## *How To Use This Manual*

---

This manual is organized for optimum use as a reference guide. Tutorials are included for those who prefer to follow a determined set of steps to accomplish a task. The manual sections are arranged as follows:

### Section 1 - Safety Information

This section gives important warnings and cautions that must be heeded when using the LSC 2000. Unit specifications are described in detail.

### Section 2 - System Setup

Included in this section are general considerations for system setup and maintenance of the unit.

### Section 3 - System Installation

This section details how to completely install an LSC 2000, as well as how to connect the LSC 2000 to certain popular gas chromatographs and accessory modules.

### Section 4 - Microprocessor Programmable Control

This section illustrates the physical qualities of the microprocessor's keypad and screens, as well as outlining how to do a run, how to program the microprocessor to handle four separate Methods and how to configure the system to acknowledge peripherals.

### Section 5 - Routine Operating Procedures

The purpose of this section is to detail the normal operating procedures of the LSC 2000. The procedures described are general and are offered as a guide for familiarizing the operator with the unit.

### Section 6 - General Maintenance

Routine maintenance procedures necessary to the efficient and safe operation of the LSC 2000 are outlined in this section.

### Section 7 - Troubleshooting

Potential problems with the unit itself and with results the unit produces are discussed in this section. The electronic and pneumatic functions of the 2000 are covered.

### Section 8 - LSC 2000 Figures

Photographs, charts, and line drawings are included to enhance understanding of the 2000's gas flow paths, replaceable parts, etc.

# TABLE OF CONTENTS

## **SECTION 1 - SAFETY INFORMATION**

- 1.1 Warnings ... 1
- 1.2 Specifications ... 2

## **SECTION 2 - SYSTEM SETUP**

- 2.1 Unpacking ... 4
- 2.2 Recommended Operation ... 4
- 2.3 General Information ... 5
- 2.4 Site Preparation ... 5
- 2.5 Power Requirements ... 5
- 2.6 Kit Box Assembly ... 6
- 2.7 Glassware Installation ... 7

## **SECTION 3 - SYSTEM INSTALLATION**

- 3.1 Purge Gas Connection ... 9
- 3.2 Pneumatic Interconnection to the Gas Chromatograph ... 9
  - 3.2.1 Connection of the Heated Transfer Line ... 10
  - 3.2.2 Connection of the GC Carrier Gas Supply ... 12
  - 3.2.3 Connection to Packed Column Injection Ports ... 12
  - 3.2.4 Connection to Capillary Columns ... 13
  - 3.2.5 Connection to the Capillary Interface ... 14
  - 3.2.6 Connection Points on Specific Gas Chromatographs ... 15
- 3.3 Leak Checking ... 16
- 3.4 Changing the Trap ... 17
- 3.5 Handling Fused Silica Tubing ... 19
- 3.6 Connecting the Drain Tubing ... 20
- 3.7 Electronic Interconnection to the Gas Chromatograph ... 20
- 3.8 Replacing the Microprocessor ROM ... 20a, 20b

## **SECTION 4 - MICROPROCESSOR PROGRAMMABLE CONTROL**

- 4.1 General Description ... 21
  - 4.1.1 The Microprocessor ... 21
  - 4.1.2 Serial (RS232C) Output ... 22
  - 4.1.3 Keypad Description ... 23
- 4.2 Program Panel ... 26
  - 4.2.1 Program Panel Description ... 27
  - 4.2.2 Program Steps ... 27
- 4.3 Powering Up the System ... 32
  - 4.3.1 Running Self Tests ... 32
  - 4.3.2 Changing the Viewing Angle of the Screen ... 33
  - 4.3.3 Loading the Method Default Values into RAM ... 34

- 4.4 Running a Default Program ... 35
  - 4.4.1 Performing a Run Using Method 1 ... 35
  - 4.4.2 Performing a Run Using Method 2, 3, or 4 ... 38
  - 4.4.3 Interrupting a Run ... 41
  - 4.4.4 Aborting a Run ... 41
  - 4.4.5 Reviewing and Resetting the Clock ... 42
  - 4.4.6 Reviewing and Changing Instrument Configuration ... 43
  - 4.4.7 Reviewing Parameter Temperature Values ... 45
- 4.5 Modifying a Program ... 46
  - 4.5.1 Setting New Values for Method Parameters ... 46
  - 4.5.2 Using STEP TO STANDBY ... 49
  - 4.5.3 Using STEP TO BAKE ... 50
  - 4.5.4 Activating Auto Drain ... 50
  - 4.5.5 Activating Bake Gas Bypass ... 51
- 4.6 System Faults and Failure ... 51
  - 4.6.1 Interpreting Invalid Input ... 52
  - 4.6.2 Restarting After Power Loss ... 53
  - 4.6.3 Running Self Tests ... 54

## ***SECTION 5 - ROUTINE OPERATING PROCEDURES***

- 5.1 Preparing Blank Water ... 56
- 5.2 Preparing a Standard ... 56
- 5.3 Loading a Sample ... 57
- 5.4 Loading a Standard ... 59
- 5.5 Quantitating a Run ... 59
- 5.6 Using Blanks ... 59
- 5.7 Selecting Operating Parameters ... 60
  - 5.7.1 Parameters for EPA Procedures ... 64

## ***SECTION 6 - GENERAL MAINTENANCE***

- 6.1 Changing the Trap ... 65
- 6.2 Conditioning a New Trap ... 66
- 6.3 Cleaning the Sample Lines ... 67
- 6.4 Cleaning Glassware ... 67
- 6.5 Ordering Replacement Parts ... 68

## ***SECTION 7 - TROUBLESHOOTING***

- 7.1 Electronic Problems ... 74
  - 7.1.1 Fuse Ratings ... 78
  - 7.1.2 Heater Resistance Values ... 78
  - 7.1.3 DIP Switch Settings ... 78

## ***SECTION 8 - LSC 2000 FIGURES***

### ***INDEX***





**SECTION 1**  
**SAFETY INFORMATION**

---

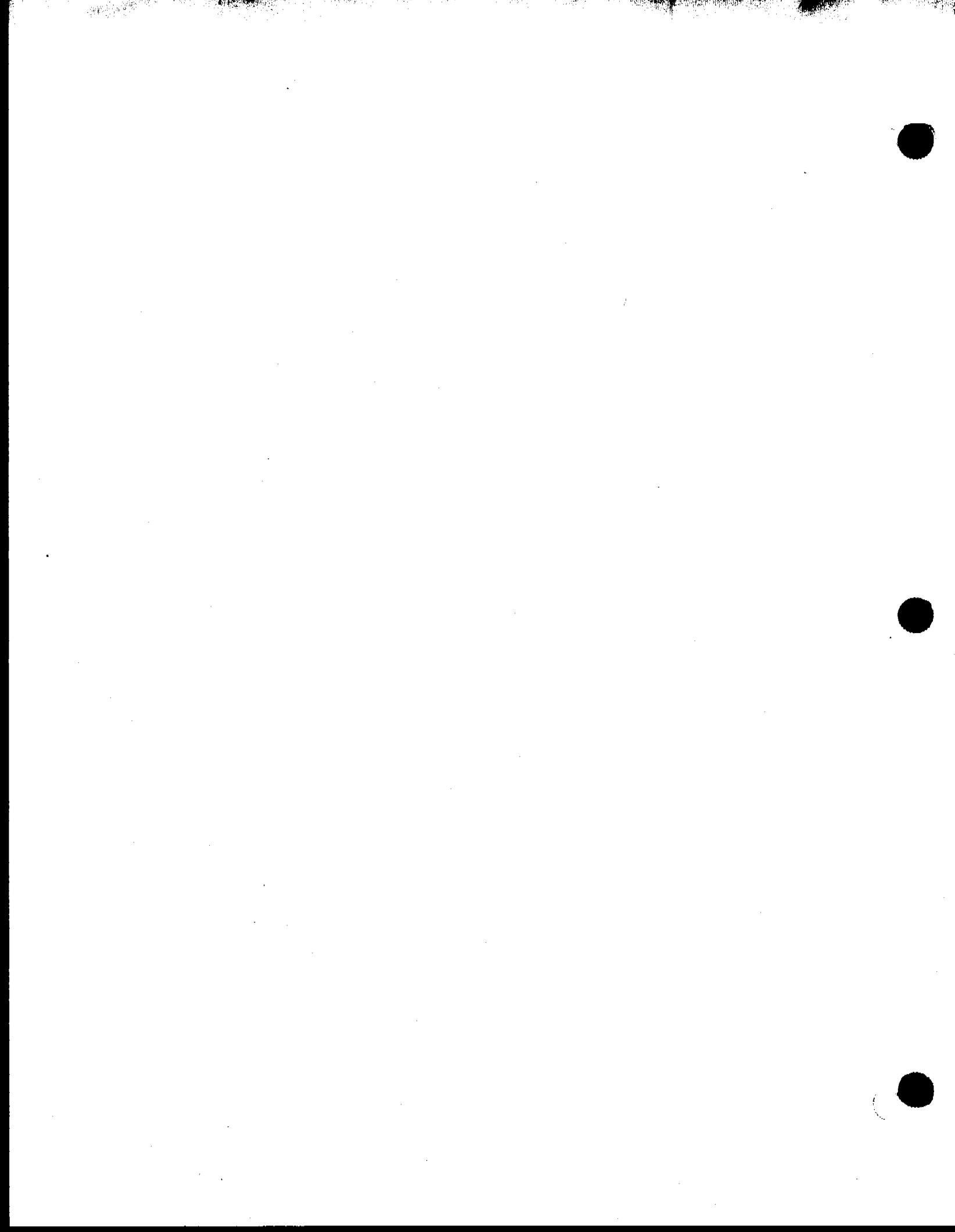

## 1.1 Warnings

The LSC 2000 meets Class 1 safety requirements.

**= WARNING =**

This instrument contains a heater. Touching the heater while in operation could cause a burn. When operating the LSC 2000, keep the trap heater door closed. The heater is on and hot in the following operating modes:

DESORB PREHEAT  
DESORB  
TRAP BAKE

The transfer line heater is on whenever the line heater set point is above 30°C. When working near this line, turn the unit off to prevent contact with the hot line.

**= WARNING =**

Potentially lethal voltage exists inside this instrument. The trap heater door and the panels must be closed when the instrument is in operation.

***ALWAYS UNPLUG THE UNIT FROM ITS POWER SOURCE BEFORE SERVICING.***

**= WARNING =**

This equipment generates, uses, and can radiate radio frequency energy. If it is not installed and used in accordance with the manual, it may cause interference to radio communications. As temporarily permitted by regulation it has not been tested for compliance with the limits for Class A computing devices pursuant to Subpart J of Part 15 of FCC rules, which are designed to provide reasonable protection against such interference. Operation of this equipment in a residential area is likely to cause interference in which case the user, at his own expense, will be required to take whatever measures may be required to correct the interference.

## 1.2 Specifications

<b>Furnace:</b>	Ambient to 400°C, rise rate approximately 200°C/min.
<b>Traps:</b>	0.123" ± 0.002" OD x 12" long x 0.010" wall thickness stainless steel standard. Optional traps include 0.125" O.D. x 1.8 mm I.D. x 12" long glass-lined stainless steel, 0.125" O.D. x 1.8 mm I.D. x 18" long glass or glass-lined stainless steel, U-shaped.
<b>Samplers:</b>	5 or 25ml sampler volume. All glass construction using medium porosity glass frits. Includes manual 3-way valve for sample load/drain. Optional 5 or 25ml needle sparge sampler.
<b>Valving:</b>	Motor-actuated 6-port valve contained in oven for purge and desorb cycles, variable ambient to 300°C. Solenoid-operated 2- and 3-port valves for purge, dry purge, drain, bake and vent functions. Solenoid valves are rated to 20 psi.
<b>Tubing:</b>	All sample lines are 1/16" glass-lined stainless steel or fused silica (0.32mm or 0.53mm I.D.), heated, variable ambient to 300°C. Sample flow pathway fittings are gold-plated. The transfer line is available in a 36", 48", or 60" length. Mount temperature is ambient to 200°C.
<b>Electronic Control:</b>	CMOS 8 bit 6303 microprocessor with 32K ROM (Read Only Memory) and 2K RAM (Random Access Memory). Parameter entry is via a tactile response panel including a numeric keypad.
<b>Outputs:</b>	Two second contact closure or contact opening, available at the Start of Desorb and at the End of Desorb.
<b>Inputs:</b>	Accepts contact closure, contact opening, or TTL input to advance from Purge Ready to Purge and from Desorb Ready to Desorb Preheat.
<b>Display:</b>	64 x 240 pixel dot graphics LCD screen.

**Serial Interface:**

RS232C serial communications port permits parameter output. Baud rate variable 150 to 19200, software selectable.

**Environment  
Requirements:**

Operating temperature: 19° to 30°C  
Storage temperature: -20° to 60°C  
Relative humidity: 10 to 90% with no condensation.

**Size:**

Depth 14" (356mm), Width 11" (280mm),  
Height 22-3/4" (578mm).

**Weight:**

Net 40 lbs., Shipping weight 50 lbs.

**Utilities:**

Voltage: 120V ± 10%, 960W  
Frequency: 50 or 60 Hz + 1%  
Purge gas: Ultra high purity (99.999%) helium or nitrogen, 20 to 200psi. Hydrocarbon content <0.5 ppm.



**SECTION 2**  
**SYSTEM SETUP**

---

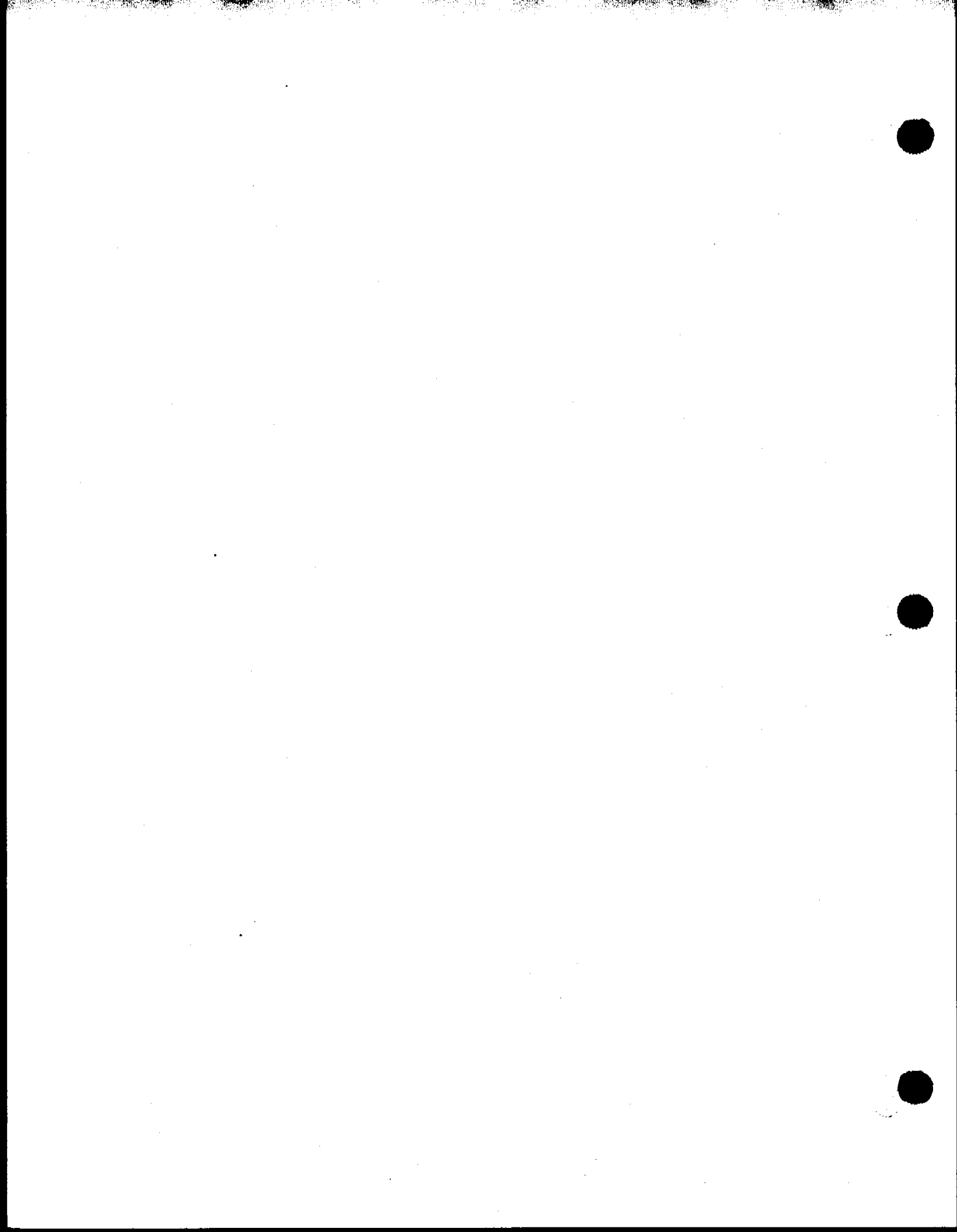



## 2.1 Unpacking the System

Remove the accessory packages and the instrument from the shipping container.

### \*\*\* IMPORTANT \*\*\*

Carefully examine the instrument. If there is visible damage to the instrument or to the accessories, notify both the shipping carrier and Tekmar Company immediately. Do not continue the installation until directed to do so by a Tekmar Representative. Failure to comply with these instructions may void your warranty for components damaged in shipment. *Do not return any materials to Tekmar Company without prior authorization.*

Save all shipping materials until proper operation of the instrument is verified.

### \*\*\* ATTENTION \*\*\*

**The LSC 2000 is delivered with a blank trap installed.** This prevents the damage that would be done to a packed trap if the unit was powered up with no purge gas flow present. ***Replace the blank trap with a packed trap before running a sample.***

## 2.2 Recommended Operation

Tekmar Company strongly recommends that the LSC 2000 be kept *on at all times* (other than when it is being serviced, during power failure, etc.) for best possible unit longevity and reliability.

Frequent power down and power up causes undue wear and tear of the unit. Repeated expansion and contraction of components as they are heated and cooled compromises the integrity of the unit's parts. This physical stress manifests itself most often in two ways. First, gas fittings are more likely to leak (this is particularly true of the ferrules that seal the glass lines in the valve oven). Second, undue stress is put on the unit heaters each time they go from room temperature to set temperature. This stress may eventually cause deterioration of the heated lines. Maintain the LSC 2000 at as constant a running state as possible and it will provide years of reliable service.

### 2.3 General Information

The system setup and installation sections are intended to be as thorough as possible. However, certain items will vary depending upon the make and model of the gas chromatograph and the data system used. If in doubt on any point, please contact Tekmar toll free at (800) 543-4461, in Ohio (800) 344-8569, or in Canada call collect (513) 761-0633 for assistance. When installation is not directed or performed by Tekmar personnel, the operator must be thoroughly familiar with the setup and installation sections of this manual and all relevant sections of the gas chromatograph manual before proceeding.

### 2.4 Site Preparation

Place the instrument on a sturdy, stable bench surface immediately adjacent to the gas chromatograph. Be sure that it is located on the side closest to the intended injection port. Allow sufficient space at the rear of the instrument for easy access and ample air circulation. Allow approximately 2 ft. of clearance to the left of the instrument for easy access to the valve oven during installation if the LSC 2000 is located to the right of the GC.

### 2.5 Power Requirements

The 110V unit requires a 50 or 60 Hz single phase power source at  $120V \pm 10\%$ . The 220V unit requires a 50 or 60 Hz single phase power source at  $220V \pm 10\%$ . For the 110V unit, the maximum current draw is 8 amps and maximum power consumption is 960 watts (when accessories are included). For the 220V unit, the maximum current draw is 4 amps and maximum power consumption is 880 watts (when accessories are included). The 110V unit power cord is terminated with a 3-prong straight blade plug and requires a matching receptacle. The 3-prong plug is a safety feature. Do not circumvent its purpose by using it with an inappropriate receptacle.

*Make all pneumatic connections **before** the instrument is powered up.*

## 2.6

Kit Box  
Assembly

Each LSC 2000 is accompanied with a kit box assembly which contains parts and tools needed to install the unit. *Check to be sure that all necessary items are included before beginning installation:*

<input type="checkbox"/> Tenax trap, 12", (#1)		#12-0083-003
<input type="checkbox"/> Tenax/Silica gel trap, 12", (#2)		#12-0084-003
<input type="checkbox"/> Fritted sparger, 5ml		#14-2337-024
<input type="checkbox"/> 3-port valve assembly		#14-3128-000
<input type="checkbox"/> Long nut, Valco, 1/16"		#14-0242-016
<input type="checkbox"/> Ferrule, Teflon, Valco, 1/16"	(2)	#14-3097-016
<input type="checkbox"/> Wago tool for thermocouple connector		#14-3046-035
<input type="checkbox"/> Hydrocarbon trap assembly		#14-1362-000
<input type="checkbox"/> Drain line assembly		#14-3367-002
<input type="checkbox"/> Purge line assembly		#14-2988-000
<input type="checkbox"/> Syringe, 5ml, w/luer connector		#14-0069-052
<input type="checkbox"/> Syringe, 10ml		#14-0089-052
<input type="checkbox"/> Union, brass, 1/8"		#12-0073-016
<input type="checkbox"/> Union, SS, Swagelok, 1/16",w/o ferr.		#14-3404-016
<input type="checkbox"/> Ferrule, 0.5mm graphitized vespel	(5)	#14-0540-016
<input type="checkbox"/> Ferrule, 0.8mm graphitized vespel	(5)	#14-2074-016
<input type="checkbox"/> Ferrule, 1/16" graphitized vespel	(5)	#14-2931-016
<input type="checkbox"/> Fused silica tubing, 0.32mm I.D. x 5M		#14-3592-002
<input type="checkbox"/> Fused silica tubing, 0.53mm I.D. x 5M		#14-3591-002
<input type="checkbox"/> Fuses	(20 total)	
<input type="checkbox"/> 1.0 amp (110V & 220V unit)	(5)	#14-0065-034
<input type="checkbox"/> 8.0 amp (110V unit)	(5)	#14-3043-034
<input type="checkbox"/> 4.0 amp (220V unit)	(5)	#14-3361-034
<input type="checkbox"/> 2.0 amp (110V & 220V unit)	(5)	#14-0140-034
<input type="checkbox"/> Cap nut, brass, Swagelok, 1/16"		#14-2792-016
<input type="checkbox"/> Ferrule, Teflon, Valco, 1/2"	(2)	#14-3098-016
<input type="checkbox"/> Sample nut, Valco, 1/2"		#14-3181-016
<input type="checkbox"/> Sample Heater		#14-3308-000
<input type="checkbox"/> Wrench, Allen		#14-0067-027
<input type="checkbox"/> Power cord, universal		#14-0298-039
<input type="checkbox"/> Screwdriver, Phillips head		#14-2987-000
<input type="checkbox"/> Sample mount wrench		#14-3145-000

Six tools are necessary for installation of the 2000 that are **not Included** in the kit box. Make sure you have them on hand.

Open-end wrench, 7/16"	(2)
Open-end wrench, 5/16"	(2)
Open-end wrench, 1/4"	(1)
Flathead screwdriver	(1)

## 2.7 Glassware Installation

### Fritted Disc Sparger

Attach the sampler body at the bottom port of the sampler mount. Slide the sampler all the way through the nut and ferrule until it contacts the inside lip of the fitting, then back the sampler out approximately 1/16". Tighten the fitting 1/4 turn past finger tight. Slide the sample needle into the top of the mount until the tip of the needle just touches the bottom of the sampler. Tighten the stainless steel nut and teflon ferrule into the top of the sampler mount to secure the needle.

**NOTE:** Take care when tightening the fitting. Overtightening will damage the teflon ferrule and may cause a leak.

Slide the sample valve bracket assembly over the front panel studs. Tighten the sampler needle into the bottom part of the sample valve. Secure the valve bracket with the two knurled nuts provided.

**NOTE:** If you need a part number for a component shown here, please refer to the Flow Diagram in Section 8.

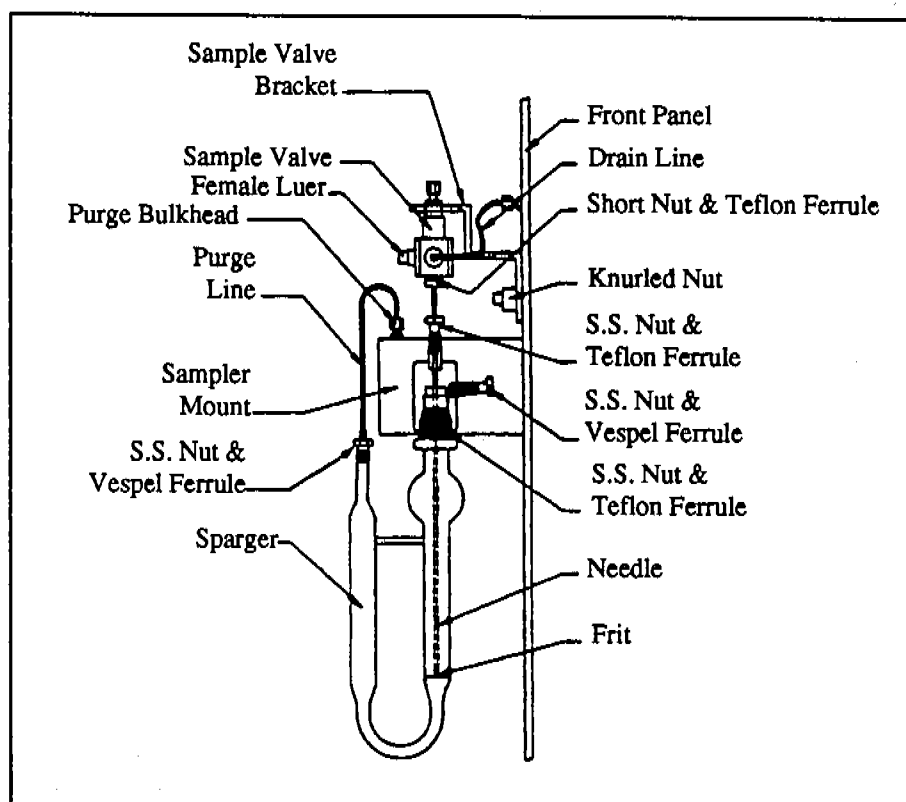

## 2.7 Glassware In- stallation (cont.)

Attach the purge line to the bulkhead union which is immediately to the right of the sampler mount. Carefully insert the septum on the other end of this line into the glassware. It may be helpful to wet the septum first to make insertion easier. Attach the drain line to the fitting labeled "Drain". Connect the other end of this line to the port on the left side of the sample valve. Leak check according to Section 3.3.

### Needle Sparger

Needle sparger glassware is installed in the same fashion as fritted disc glassware except that the sampler needle should be adjusted so that the needle is as close to the bottom of the glassware as possible without obstructing the orifice.

**NOTE:** For analyses that do not require the addition of water, remove the sample needle before adding the sample to the glassware. (This keeps the sampler needle clean for applications where it will actually be used). Remove the stainless steel nut and teflon ferrule at the top of the sample mount and replace them with a plug nut.

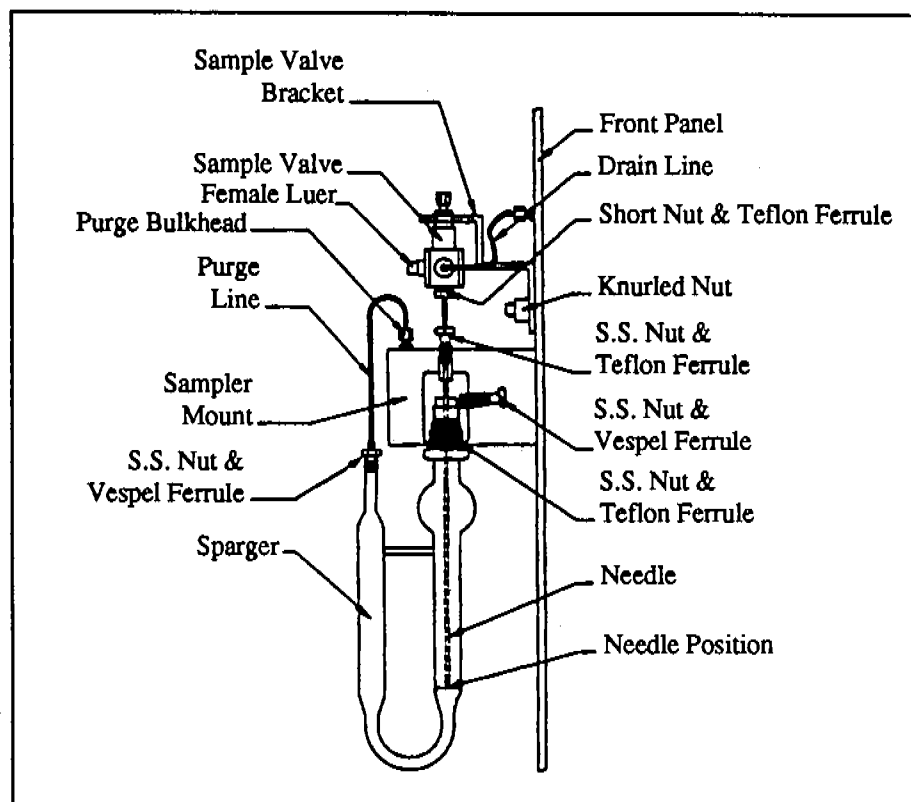

**NOTE:** If you need a part number for a component shown here, please refer to the Flow Diagram in Section 8.



**SECTION 3**  
**SYSTEM INSTALLATION**

---





### 3.1 Purge Gas Connection

**NOTE:** Complete all the pneumatic connections before powering up the system.

The concentrator requires a high purity (99.999%, hydrocarbon-tested, or better) helium or nitrogen (do not use argon/methane) gas supply at 20-200 psi. This is usually supplied via a tee union from the same tank that supplies the GC carrier gas. Connect the purge gas line to the hydrocarbon trap included in the kit box assembly. Continue the Purge gas line from the hydrocarbon trap to the fitting marked "Purge" at the rear of the concentrator. Turn on the gas supply, set the purge pressure on the front of the LSC 2000 to 20 psi, and do a leak check (See Section 3.3).

**NOTE:** It may be most convenient to leak check all fittings simultaneously after installation is complete.

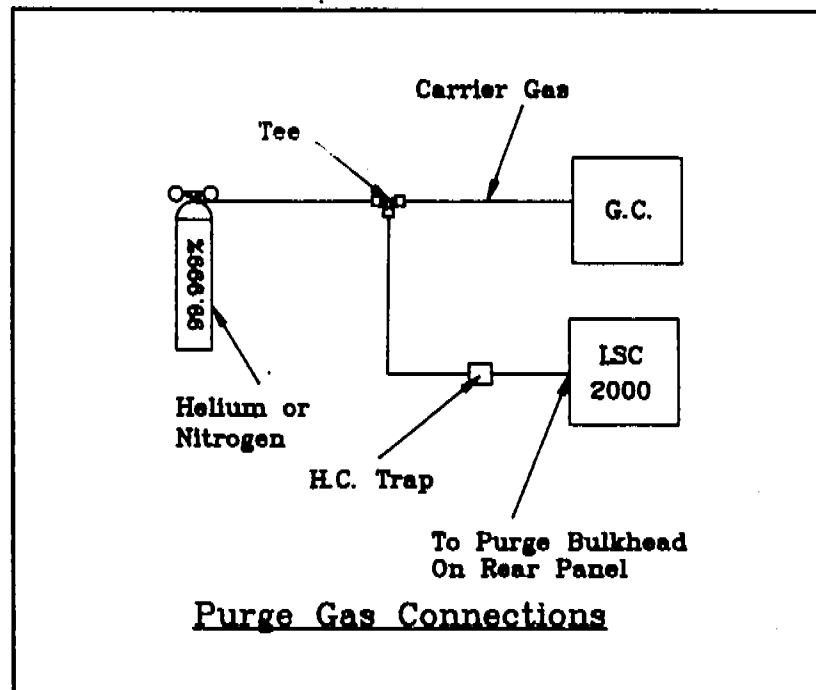

### 3.2 Pneumatic Interconnection to the Gas Chromatograph

Different chromatographs require different means of connection. Installation instructions for specific gas chromatographs are supplied with the cable interfaces necessary to your particular system configuration. To properly complete an installation, it is helpful to understand exactly how the GC will operate with the concentrator attached.

**3.2  
Pneumatic  
Interconnection  
to the Gas  
Chromatograph  
(cont.)**

When the GC is connected to a concentrator, the GC continues to supply and control the carrier gas. Note that the carrier gas supply is always independent of the purge gas supply.

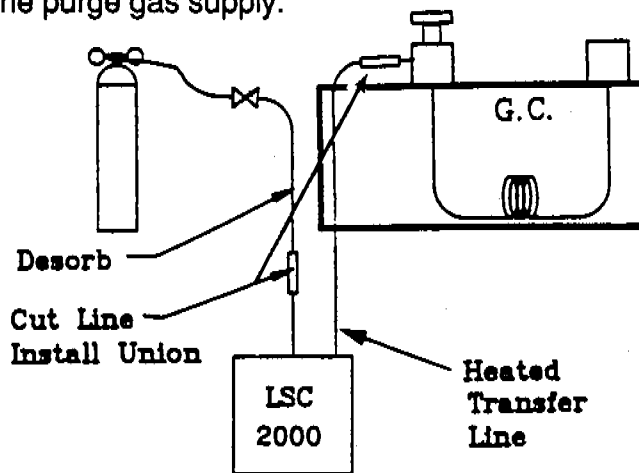

The carrier gas will be rerouted out of the GC to the concentrator close to where it would normally enter the body of the injection port. The carrier gas now passes through the 6-port valve in the concentrator and returns via the heated transfer line.

No controls are placed on the carrier gas during its loop through the concentrator. Normal GC function is unimpaired by installation of a concentrator (except when a Capillary Interface is being used. See your Capillary Interface Manual for further information). The transfer line is either connected to the line entering the injection port where the carrier gas is normally supplied (for packed and some wide-bore capillary columns) or is passed through a capillary interface and then directly into a capillary column.

**CAUTION:** This instrument contains glass-lined tubing, which is extremely fragile. If the tubing is bent, it will fracture. (Glass-lined tubing can be identified by its blackened appearance.)

Uncoil the line heater. Normally only one transfer line is included with the LSC 2000, depending on how the instrument was ordered.

**3.2.1  
Connection of  
the Heated  
Transfer Line**

### 3.2.1 Connection of the Heated Transfer Line (cont.)

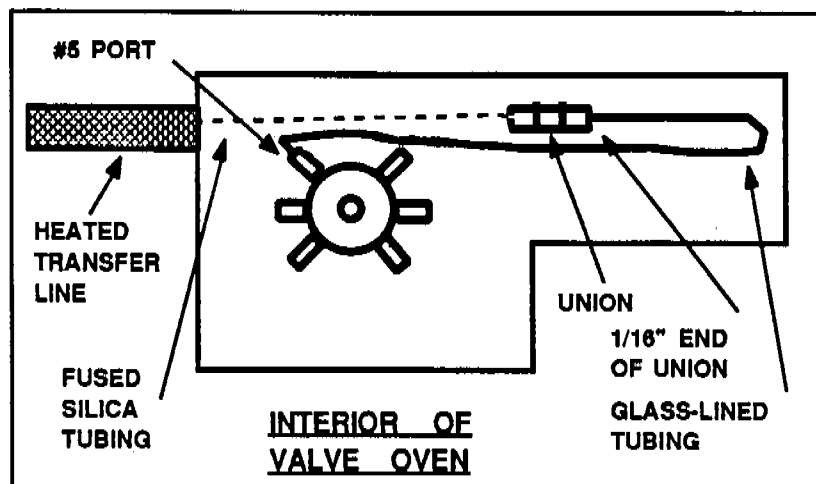

Pass a length of fused silica tubing through the heated transfer line. The internal diameter (I.D.) of the fused silica should be as small as possible without restricting the carrier gas flow. For packed columns use 0.53mm I.D., for 0.32mm and larger capillary columns use 0.32mm, for all others use 0.20 mm. Remove the left side panel by turning its four Phillips head screws 1/4 turn each. Slide the panel straight back and then lift it out to the left, away from the unit. Remove the furnace cover by turning the two front panel screws, then sliding the cover forward and out. Remove the valve oven cover by turning the two Phillips head screws at the top of the oven 1/4 turn with the long-handled screwdriver supplied in the Kit Box and by unscrewing the two flathead screws at the bottom of the valve cover. Locate the glass-lined tubing coming out of the #5 port on the 6-port valve. (See LSC 2000 Valve Oven Diagram) Install the 1/16" stainless steel Swagelok union to the free end of the glass-lined tubing, being sure to include a 1/16" graphitized vespel ferrule. Slide the fused silica tubing (in the diameter appropriate to your application) through the heated transfer line (on the back of the unit) until it enters the valve oven. Connect this fused silica tubing to the free end of the union you have just installed, using another graphite/vespel ferrule which matches the size of the fused silica you have chosen. Leave the valve oven cover off until all of the fittings have been leak checked (See Section 3.3).

### 3.2.2 Connection to the GC Carrier Gas Supply

If a column is already installed in the GC, turn off the oven and allow it to cool to room temperature. The carrier gas supply will be interrupted during installation so the column must be cool to avoid damage. Determine which injection port will be interfaced. Remove the covers around the injector to expose the tubing which supplies the carrier gas. This line must be opened either by disconnecting a union (if present) or by cutting the tubing. If no union is present, or if the tubing from the injector to the union exceeds a reasonable length, the cut should be made as close as possible to the injector body, allowing enough length to install a Swagelok union. Connect a piece of 1/8" copper tubing to the line that was originally connected to the injection port (i.e. the line that is supplying the carrier gas). Connect the other end of this copper tubing to the bulkhead union on the rear of the concentrator labeled "Desorb". Briefly turn on the carrier gas and confirm the presence of flow at the end of the heated transfer line. This can easily be determined by holding the end of the line in a small beaker of water. If there is flow, the installation is correct to this point. If no flow exists, there is a wrong connection, a large leak, or a broken line. Carefully examine the installation until the problem is located.

### 3.2.3 Connection to Packed Column Injection Ports

**NOTE:** This section includes wide-bore capillary columns installed in packed column injectors with adaptors.

Locate the stainless steel line entering the injection port (See Section 3.2.2). Connect the heated transfer line from the concentrator to this stainless steel line. Since the injection port line is metal, trim the tubing back to minimize any unheated length. Using 1/16" stainless steel ferrules, connect the tubing to a stainless steel union only, and connect this to the line entering the injector. Since the heated transfer line from the concentrator is fused silica, use a graphitized vespel ferrule. The transfer line should be secured in a manner which removes all strain from the

### 3.2.3 Connection to Packed Column Injection Ports (cont.)

fused silica tubing. Carefully leak check all of the fittings according to Section 3.3.

The fittings that should be checked include: The carrier gas to the concentrator, the Desorb bulkhead union, the transfer line to the 6-port valve, and the transfer line to the injector. If the injection port is equipped with a septum purge function, this must be turned off or capped. If the septum purge is active it will act as a leak and will result in a loss of sensitivity on concentrator runs.

### 3.2.4 Connection to Capillary Columns

There is a variety of methods by which installation to capillary columns may be accomplished. If an injection port is used, e.g. wide bore column with adaptors in a packed injector, or a capillary injector operated with subambient temperature, refer to Section 3.2.3. In some cases it may be desirable to connect the transfer line directly to the end of the column. This connection should be made inside the oven. Use a fused silica transfer line only. The line should be of a size equal to or smaller than the I.D. (internal diameter) of the column. Route the transfer line through any convenient opening in the oven (unused injection ports are suitable and handy, for example) until the heater butts against the outside of the oven. If no ready-made openings are available, small holes can usually be drilled through the oven insulation near the injectors or the detectors. Connect the transfer line to the column using a zero dead volume union. Make this connection as described in Section 3.5. Anchor the transfer line with a clamp to prevent the fused silica tubing from being broken where it enters the oven.

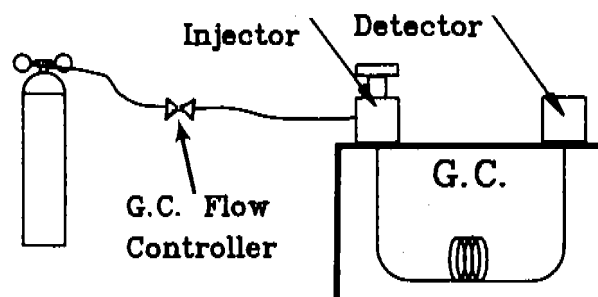

Normal G.C. Configuration

**3.2.5  
Connection to  
the Capillary  
Interface**

These instructions have been revised. Please refer to the directions in the Capillary Interface Accessory Instruction Manual in the Accessories Section of this manual.

**3.2.6  
Connection  
Points on a  
Specific Gas  
Chromatograph**

Pneumatic connection points on gas chromatographs are specific to each particular make and model of gas chromatograph available. Instructions for pneumatically connecting an LSC 2000 to a particular gas chromatograph accompany the interface cables necessary to the installation you described when you placed your order. If you did not specify the type of G.C. being used with your system you will need to call Tekmar to order an interface cable.

### 3.3 Leak Checking

The 2000 is not a leak prone system, however, it is very leak sensitive. Utmost care should be taken to ensure that the system is leak tight. All fittings should be thoroughly leak checked.

The simplest and most effective way to leak check a system is by bubble leak check. Place a 1/16" Swagelok cap nut (included) on the LSC 2000 vent fitting and tighten it wrench tight. Put 5ml of organic free water in the purge vessel. Press **STEP** to advance the unit to Purge mode. Press **HOLD** to keep the system in Purge mode. This procedure causes the system to pressurize. Time the bubbling in the purge vessel.

If the bubbling stops between 2 to 5 minutes, the system is leak tight and no further leak checking is necessary. In this case, press **STEP TO STANDBY** twice and return the unit to Auto mode.

If the bubbling stops before 2 minutes has elapsed, it is likely that there is a leak upstream of the purge vessel (before the gas flow reaches the purge vessel). If a leak is indicated, leave the system in purge with the cap on the vent. Capping the vent causes an increase in pressure which will exaggerate the leak and make it easier to find.

**NOTE:** First make sure the leak is not at the capped vent. The Swagelok nut may be worn out.

If the bubbling continues after 5 minutes, a leak downstream of the purge vessel is indicated (after the gas flow leaves the purge vessel).

**CAUTION:** Do *NOT* use any type of soap solution (e.g. Snoop or Detect) to leak check. If these solutions get into the lines, increased background and adsorption are likely to occur.



### 3.3 Leak Checking (cont.)

Leak checking is best accomplished with an electronic thermal conductivity detector.

**NOTE:** Electronic detectors do not work well when using nitrogen as the purge gas. If possible use helium when leak checking.

If an electronic leak detector is not available, a 1:1 solution of isopropanol:water may be used, if done so sparingly.

- 1) Remove the trap cover at the front left side of the unit. Check the fittings at the top and the bottom of the trap.
- 2) Check the 5 fittings around the glassware on the front of the unit.
  - a. purge glassware fitting
  - b. purge bulkhead (at unit)
  - c. sample glassware fitting
  - d. sample needle nut
  - e. sample valve 3 port
- 3) Check the purge bulkhead and the sample bulkhead fittings on the inside of the front panel of the LSC 2000.
- 4) Remove the valve oven cover and check the 10 fittings inside the valve oven. (See LSC 2000 Valve Oven Diagram) The trap cover must be off to remove the left side panel that covers the valve oven cover.
- 5) Remove the right side panel and check the 18 Swagelok fittings inside the unit. (See Swagelok Leak Check Diagram)

### 3.4 Changing the Trap

#### New Installations

**The LSC 2000 is delivered with a blank trap installed.** This prevents the damage that would be done to a packed trap if the unit was powered up with no purge gas flow present. *Replace the blank trap with a packed trap before running a sample.*

**3.4  
Changing the  
Trap (cont.)**

How to identify a trap

Traps can be identified by a number stamped on the nut at the bottom of the trap. These numbers are:

<u>Trap Number</u>	<u>Part Number</u>	<u>Type of Trap</u>
0	14-1168-003	Blank
1	12-0083-003	Tenax
2	12-0084-003	Tenax/Silica Gel
3	14-0124-003	Tenax/Silica Gel/ Charcoal
4	14-1457-003	Tenax/Charcoal
5	14-2366-003	OV1/Tenax/Silica Gel/Charcoal
6	14-1755-003	OV1/Tenax/Silica Gel
9	Custom	

How to change a trap

- 1) Remove the trap door at the front end of the left panel.
- 2) ***Make sure the trap is not hot.***
- 3) If you have already powered up the unit, make sure the system is in Purge Ready or Standby.
- 4) Loosen the nut at the top of the trap one full turn but do not remove it completely.

**NOTE:** The nut at the top of the trap should have been fastened finger tight and loosened easily. If not, the ferrule may need to be replaced.

- 5) Hold the bottom fitting in place with a 7/16" wrench while using a 7/16" wrench to turn the nut at the bottom of the trap counter-clockwise until the fitting is disengaged.
- 6) Grasp the trap furnace and trap and carefully pull the trap straight down and out of the upper trap fitting.
- 7) Grasp the trap furnace in one hand and the lower trap fitting with the other hand and pull the trap out of the furnace.
- 8) Slide a packed trap into the trap furnace sleeve.
- 9) Reconnect the top and bottom fittings. Take care

### 3.4 Changing the Trap (cont.)

not to tighten the top fitting past finger tight as this may result in damage to the teflon ferrule.

- 10) While holding the fitting in place with a 7/16" wrench, tighten the brass nut at the bottom with another 7/16" wrench one-eighth turn past finger tight.

- 11) Put the trap door back on.

***Before samples can be run, the new trap must be thermally conditioned.*** Refer to Conditioning a New Trap, Section 6.2.

### 3.5 Handling Fused Silica Tubing

Making connections with fused silica tubing is far more difficult than doing so with metal tubing. Although fused silica is flexible, it is also brittle and breakable. Care must be taken not to bend the tubing too far or it will fracture. (The minimum bend radius of fused silica tubing is: 3.5" for 0.53mm, 3.0" for 0.32mm, and 2.75" for 0.25mm I.D. tubing.) Also, the tubing must not be scratched or it is likely to break under the stress of bending or vibration that would normally have no effect.

When making a connection with fused silica tubing, use the appropriate size graphite, vespel, or graphitized vespel ferrule. Tekmar Company recommends graphitized vespel for its ease of use and reliable sealing characteristics. Place the nut and ferrule on the tube, then carefully remove a short (1-2cm) section of tubing. This ensures that no ferrule particles remain inside the tubing; these can cause severe adsorption and carryover. Cut the tubing by scoring it with a diamond-tipped pencil or another suitable device (a razor blade works well). Pull the tubing apart by lightly bending it from the side opposite the score. Make the connection with the fitting and tighten it approximately one half turn past finger tight. It may be necessary to secure the center of the union to the column cage (a bent paper clip is handy for this purpose) so that stress caused by the weight of the union is relieved.

### 3.6 Connecting the Drain Tubing

Attach a length of 1/8" I.D. plastic tubing to the fitting marked "Drain" on the back of the LSC 2000. Run this line to a sink or waste bottle.

### 3.7 Electronic Interconnection to the Gas Chromatograph

Electronic connection points on gas chromatographs are specific to each particular make and model of gas chromatograph available. Instructions for connecting an LSC 2000 to a particular gas chromatograph accompany the interface cable necessary to your specific LSC 2000 to GC setup. Every customer is encouraged to specify the setup he or she plans to use when the order for the LSC 2000 is placed so that Tekmar personnel can configure the LSC 2000 to electronically acknowledge your GC and so that it will be ready for use when it arrives. If you did not specify your setup, you will need to order an interface cable to interconnect the 2000 with your GC (If you will be using more than one GC with the 2000 you will need an interface cable for each different GC) When you receive your cable **you will also need to set the DIP switches on your LSC 2000's I/O board** to acknowledge your GC. Complete installation instructions are included with every interface cable and should be added to your LSC 2000 User Manual for future reference. Check Section 7.1.3 for further information about DIP switch settings.

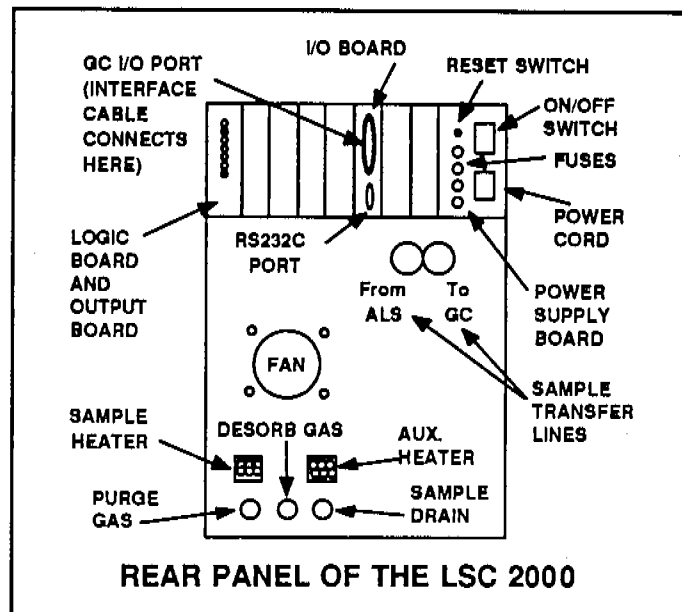

### 3.8 Replacing the Microprocessor ROM

It may be necessary to replace the microprocessor ROM chip in order to upgrade the operating parameters of the LSC 2000. When purchasing accessories for your LSC 2000, it may have been verified that an upgraded ROM chip was required. The accessories to the LSC 2000 require a minimum version of 1.3E on the ROM. Versions 1.3E or greater will appear printed in the upper right hand corner of the Configuration screen (press **F4 (Conf)** in Start Up screen). There will be no display of versions previous to 1.3E. The upgraded ROM chip should be included in a kit box assembly with your accessory. Please read the instructions carefully before attempting to replace the chip.

- 1) Unplug the power cord from the LSC 2000.
- 2) Remove the side panel adjacent to the pressure regulator and gauge.
- 3) On the ceiling of the lower compartment is a green/yellow ground wire coming from the Control Module (upper compartment). Disconnect this with a 5/16" wrench.
- 4) Remove the 4 retaining screws located on the sides of the Control Module (see the LSC 2000 Electronics Module Connection diagram) and carefully remove this module by lifting straight up on the module, making sure to guide the ground wire through the thermal barrier and retaining clip.
- 5) Lay the module on its top so that the boards and ROM chips are visible.

**NOTE:** The microprocessor board and display are mounted to the interior side of the keypad. The ROM chip resides on the microprocessor board. The location of the ROM chip is labeled on the LSC 2000 CPU Board & Keypad diagram. The ROM chip is mounted in a Z.I.F. (Zero Insertion Force) socket. The Z.I.F. socket has a lever at the one end which, when in the down position, applies force to the pins of the chip to make a connection. When the lever is in the Up position, it relieves the force on the pins and disconnects the chip for easy removal or insertion.

**3.8**  
**Replacing the**  
**Microprocessor**  
**ROM (cont.)**

**\*\*\* IMPORTANT \*\*\***

The ROM chip is a static sensitive chip. Use caution when handling the chip. Do not touch the pins of the chip.

- 6) To remove the old ROM, lift up the lever on the Z.I.F. socket and remove the chip by holding each end of the ROM chip and pulling it straight out.
- 7) Take note that the ROM chip has a u-shaped groove at one end. This end of the chip goes toward the lever of the Z.I.F. socket. Insert the new ROM chip holding the ends of the chip.
- 8) Align the pins on the chip with the sockets and carefully insert the chip, *making sure not to bend the pins*, until it seats. With finger pressure still being applied, push the Z.I.F. lever down to lock the ROM chip in place.
- 9) To replace the Electronic Control Module on the unit, follow the removal procedure in reverse, making sure you run the green/yellow ground wire thru the retaining clip and down thru the hole to the lower compartment.

**NOTE:** It will be necessary to re-program all parameters once the instrument has been re-installed.

**SECTION 4**  
**MICROPROCESSOR**  
**PROGRAMMABLE CONTROL**

---

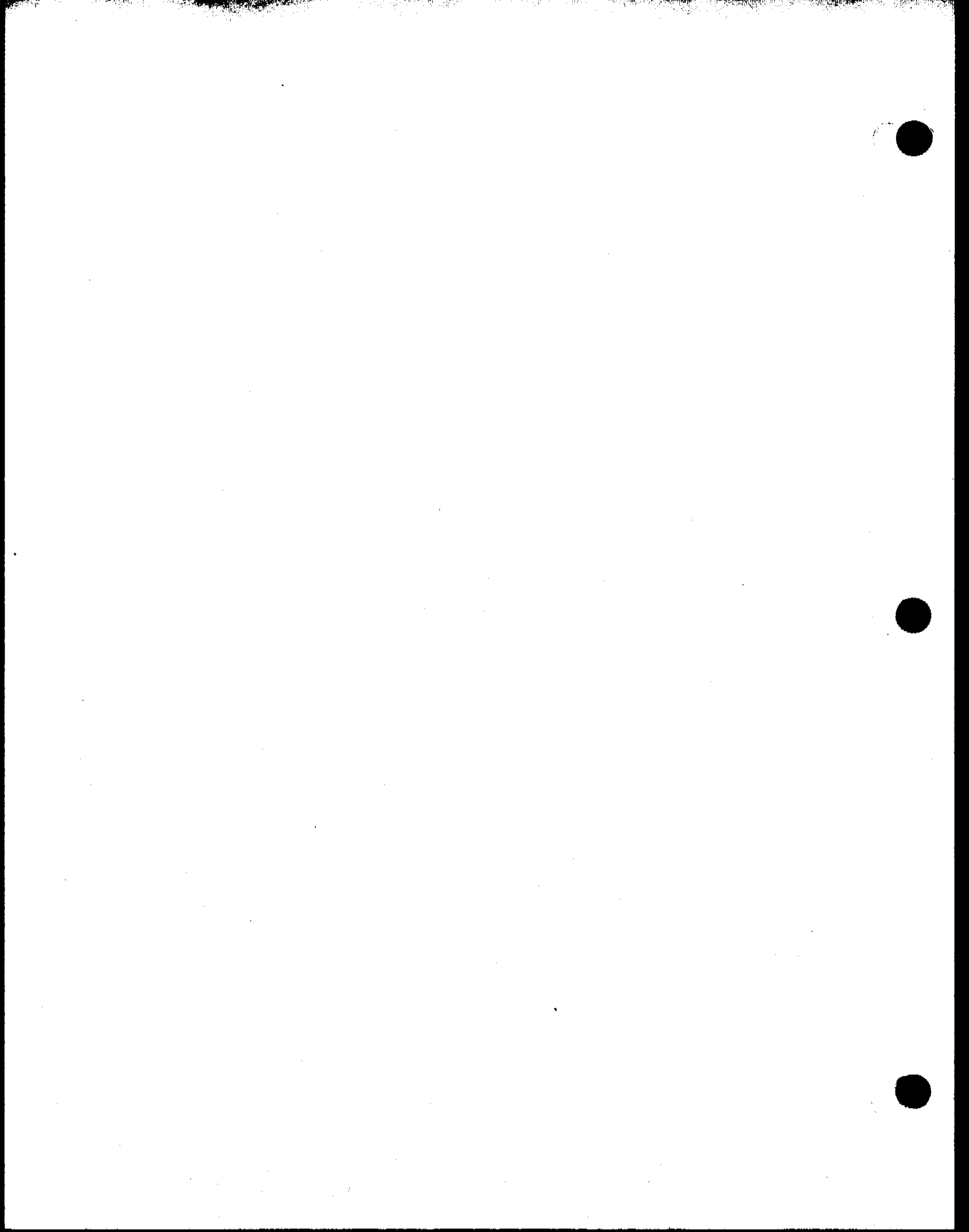



## 4.1 General Description

The LSC 2000 microprocessor programmable control consists of:

- an 8 bit microprocessor with 32K of program ROM (Read Only Memory), 2K of RAM (Random Access Memory), and analog input through which the microprocessor receives information from its peripheral devices (for example, heater thermocouples),
- a membrane keypad with which values for program parameters may be modified,
- and a six line LCD (Liquid Crystal Display) that displays the various steps of program execution.

### 4.1.1 The Microprocessor

The controller uses a 6303 eight bit CMOS-type microprocessor to manage the operation of the various functions of the system. The introductory system screen looks like this:

Tekmar LSC 2000  
Automatic Concentrator System

Instructions for the microprocessor are stored in ROM and on each initial power-up the basic program parameters are displayed for running or modification. Battery back-up retains modified parameters when power failure occurs.

The program panel outlines the purging, desorption, and cryofocusing functions that are currently being used in EPA procedures, along with the default values for the set times and temperatures associated with each step. (See Section 4.2, "Program Panel").

The controller allows value modifications to be made to the program parameters after power-up, storing the changes in RAM. The controller can store 4 complete sets of program parameters in RAM; these are labeled Method 1, 2, 3, and 4. The defaults for each of the four methods are the same. However, each

4.1.1  
The  
Microprocessor  
(cont.)

method can be modified independently to reflect a specific set of parameter values. Because they are stored in the unit's memory, customized methods allow for greater convenience and more efficient process time. After the system displays the introductory screen, it performs self tests. Following self tests, it will display the Method 1 Start Up screen:

Start Up	Method 1
Line: 80 <sup>o</sup> > 100	Valve: 80 <sup>o</sup> > 100
BOT: 75 <sup>o</sup> > 100	Capillary
Mount: 75 <sup>o</sup> > 200	Int: 99 <sup>o</sup> > 100
Meth            ALS	Temp            Conf



The commands available for each program stage are located on the bottom line of the screen. Each command corresponds to the function key found directly beneath it. There are four keys on the keyboard that are designated as function keys. A fifth key, **ENTER**, also serves as a function (command) key, but it will be discussed when we get to "Modifying A Program," Section 4.5.

4.1.2  
Serial  
(RS232C)  
Output

The controller has a serial port that allows communications between the system and a printer. The port will provide the following data in ASCII-coded output:

- 1) Method listing:            Output occurs whenever Method is chosen.
- 2) Error/fault messages:            Output whenever a condition such as "heater fault", or "power fail", etc. are encountered.
- 3) Running state transitions:            Outputs clock time whenever the program makes a transition from one program to the next, starting with Start Up. The name of the program stage is also sent.

4.1.2  
Serial  
(RS232C)  
Output (cont.)

**Reviewing and Changing the Baud Rate**

To use a printer with the LSC 2000, the baud rate of the printer and the LSC 2000 serial port must match. From the Start Up screen, press **F4 (Conf)** to see the Current Configuration screen.

Current Configuration  
Date: 11/01/87      Time: 12:30:00  
Baud: 1200    ALS 2016: NO    ALS 2032: NO  
(PAGE DOWN for more)  
Help      LSC      Inst.    OK

Press **F2 (LSC)** to get the LSC screen:

Press **F2 (Clock)** to change time/date  
Refer to Manual Section 4.4.5  
Press **F3 (Baud)** to change the baud rate  
Refer to Manual Section 4.1.2  
**Exit**

Press **F3 (Baud)** to see the array of values for the serial port baud rate:

Baud Rate: 1200  
150            300            600            1200  
2400          4800          9600          19200  
                 <-                    ->            Exit

Press **F2 (<-)** or **F3 (->)** to highlight the desired baud rate. Press **F4 (Exit)** to go to the Method screen.

4.1.3  
Keypad  
Description

The LSC 2000 keypad is the center of control for all operator tasks.

**Tekmar**

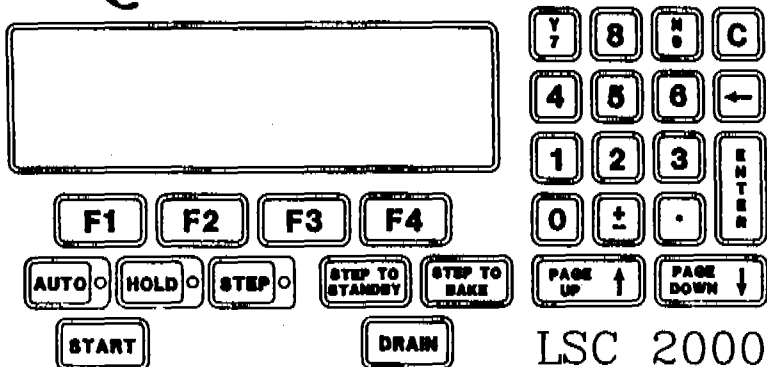

4.1.3  
Keypad  
Description  
(cont.)

The components of the keypad and their use follow.



The function keys correspond directly to commands found on the bottom line of the Liquid Crystal Display (LCD) screen. The commands available at any given time depend upon the actual program step the system is performing.



Press **AUTO** to signal the system to proceed through the run automatically.

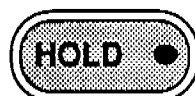

Press **HOLD** to interrupt the system at any point during a run. The system will not proceed until the operator presses **STEP**, **AUTO**, **START**, **STEP TO BAKE**, or **STEP TO STANDBY**.



Press **STEP** and release it to cause the system to immediately proceed to the next system mode.



Press **STEP TO STANDBY** to cause the system to go directly to Standby mode from whichever mode it is performing when STEP TO STANDBY is pressed. This command feature avoids 'wear and tear' of the 6-port valve and also avoids start up of the GC. Since this command terminates the run in progress, the system will display a screen asking you to confirm that you really want to abort the run. This screen setup ensures that a run is not aborted due to an inadvertent keystroke.

### 4.1.3 Keypad Description (cont.)



Pressing **STEP TO BAKE** causes the system to go directly to Bake mode from whichever mode it is performing. This feature allows the trap to be cleaned immediately, and therefore, to be prepared for another run. It is also useful for conditioning new traps.



Press **START** to signal the LSC 2000 to proceed from Purge Ready mode. A message or "prompt" appears on the LCD screen to tell the operator that the unit is ready to load the sample.



Press **DRAIN** to manually open and close the drain, causing the system to drain the sample from the unit. This feature offers the operator greater control over the exact moment a sample is drained. This is useful when the AUTO DRAIN option is turned off to enable a second run to be performed, for example.

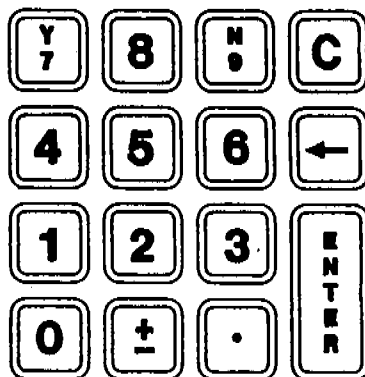

Press the numbered keys on the numeric keypad to change the values assigned to system Method parameters. Keys 7 and 9 are also used to enter "Yes" and "No" when configuring the system to acknowledge instruments that are attached to it.

4.1.3  
Keypad  
Description  
(cont.)



Press **CLEAR** or **<- (BACKSPACE)** to change or eliminate a value entered from the keypad. The value in question must be highlighted by a shaded box to be accessed from the keypad.



Press **ENTER** to fix into system memory values that have been input from the keypad. In an instance where no change to a parameter value is necessary, press **ENTER** to return to the Method Parameters listing.

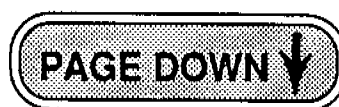

The **PAGE UP** and **PAGE DOWN** keys serve two separate functions. Press **PAGE DOWN** or **PAGE UP** to change the Viewing Angle of the LCD screen so that it can be seen clearly from an operator's sitting or standing position. When the screen prompt **<PAGE UP/DOWN for more>** appears, the keys **PAGE UP** and **PAGE DOWN** function to allow viewing of additional parts of a listing (in Method Edit, Configure, or Instrumentation, for example).

4.2  
Program Panel

The program panel consists of purge, desorption, cryofocusing, and bake procedures complete with default values for each of the program steps. Each of four methods can be run as is, or the values for each of the program steps can be modified.

**NOTE:** Prepurge and Preheat can only be run when the Sample Heater is installed.  
Cooldown and Inject can only be run when the Capillary Interface is installed.

### 4.2.1 Program Panel Description

The program panel is located on the front of the unit next to where the sample is mounted. It lists the program steps in sequence and has LEDs (light-emitting diodes) that indicate which program step is being performed. Whenever the unit is turned on, all modes on the program panel will illuminate red except one. A green LED lights up to indicate the mode the unit is in currently. If a particular mode on the panel corresponds to an accessory that is not installed, the corresponding LED will not illuminate.

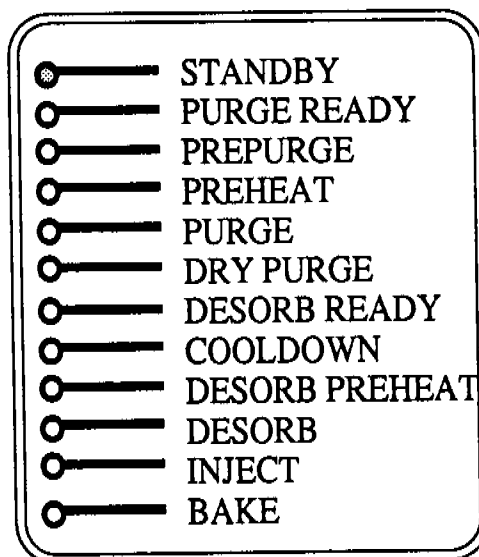

### 4.2.2 Program Steps

The following describes the tasks that are being performed by the system during each of the program steps:

#### • STANDBY

When the system is powered up, Standby establishes initial conditions for a sample run. After a run, initial conditions are recovered in this step. The LCD window displays the Line temperature, BOT (Bottom Of Trap) temperature, Mount temperature (where the sample glassware is attached), and the Valve temperature. The display shows the actual temperature to the left of the '>' symbol (which changes as the components heat up) and the set value to the right of the '>' symbol. If a Capillary Interface has been installed, "Capillary Int." will be followed by the actual temp. as it cools, and the set temperature.

4.2.2  
Program Steps  
(cont.)

<b>Start Up</b>		<b>Method 1</b>	
Line: 80° > 100		Valve: 80° > 100	
BOT: 75° > 100		Capillary	
Mount: 35° > 40		Int: 99° > 100	
<b>Meth</b>	<b>ALS</b>	<b>Temp</b>	<b>Conf</b>

The system automatically proceeds to the Standby screen, which is the second phase of Standby mode.

<b>Standby</b>		<b>Method 1</b>	
Trap: 33°		Set: < 30°	
Sample: 21°			
<b>Meth</b>	<b>ALS</b>	<b>Temp</b>	<b>Conf</b>

**NOTE:** The LSC 2000 is programmed to come up in **HOLD** as a safety measure. Press **AUTO** to cause the unit to proceed.

When all five parameters have reached their set temperatures, the Standby light on the Program Panel goes out and the Purge Ready light goes on.

• **PURGE READY**

The Purge Ready Step serves as a signal to the operator that proper conditions have been met and the unit is ready to purge the sample. At this point, the unit will pause until **START** is pressed.

<b>Purge Ready</b>		<b>Method 1</b>	
Trap: 29°		Sample: 21°	
Ready for sample to be loaded.			
Press <b>START</b> to begin run			
<b>Meth</b>	<b>ALS</b>	<b>Temp</b>	<b>Conf</b>

**NOTE:** If a sample heater is not installed, the sample temperature reads the temperature inside the unit.



4.2.2  
Program Steps  
(cont.)

• **PREPURGE**

Prepurge mode functions only when a sample heater is installed. In this mode, the purge gas is turned on before a sample is heated. This process removes oxygen from the sampler and assures that the sample is blanketed by inert gas when it is heated. The inert gas prevents oxidation of the heated sample.

Prepurge		3.51 > 4.00		
Trap: 27°				
Sample : 21°		Method 1		
Meth	ALS	Temp		Conf

• **PREHEAT**

Preheat mode functions only when a sample heater is installed. This mode heats the sample in a static condition, i.e., without purge gas flow. This process allows the sample temperature to equilibrate before purging, which enhances quantitative reproducibility.

Preheat		4.53 > 5.00		
Sample: 70°				
Set: 70°		Method 1		
Meth	ALS	Temp		Conf

• **PURGE**

In Purge mode, volatiles are removed from the sample by passing purge gas through it.

Purge		0.23 > 12.00		
Trap: 25°				
Sample: 70°		Method 1		
Meth	ALS	Temp		Conf

**4.2.2  
Program Steps  
(cont.)**

**• DRY PURGE**

In Dry Purge mode, the purge gas remains on, but flows only through the trap, bypassing the sample. This process causes water in the trap to be removed.

**NOTE:** If the trap contains silica gel, water in the trap cannot be removed.

Dry Purge		0.23 > 5.00	
Trap: 25°		III	
		Method 1	
Meth	ALS	Temp	Conf

**• DESORB READY**

In Desorb Ready the unit signals that it is ready to send the sample to the G.C.

Desorb Ready		Method 1	
		Run 1 of 1	
Waiting for GC ready signal.			
Press STEP if interface is not installed (NI).			
Meth	ALS	Temp	Conf

**• COOLDOWN**

Cooldown mode occurs only when a Capillary Interface is installed. In this mode, the sample is cryofocused (frozen) in the Interface trap in order to improve peak shape during the injection. This process concentrates the injection in order to make it most compatible with capillary column use.

Cap Cooldown		Method 1	
Valve: 100°		-100° > -120°	
Set: 100°		Injector > Set	
Meth	ALS	Temp	Conf

4.2.2  
Program Steps  
(cont.)

• **DESORB PREHEAT**

In Desorb Preheat mode, the trap is heated before the 6-port valve is switched, so that the trap is hot before the analytes are backflushed. This process improves the quality of the injection of the sample before it goes into the G.C.

Desorb Preheat	Method 1
	79° > 175°
	Trap > Set
Meth	ALS
Temp	Conf

• **DESORB**

In Desorb mode the sample is injected into the G.C.

Desorb	1.10 > 4.00
Trap: 175°	
Set: 180°	Method 1
Auto Drain: ON	
Meth	ALS
Temp	D Conf

**NOTE:** The flashing 'D' between (Temp) and (Conf) on the LCD screen indicates that the drain is open. Press **DRAIN** to close or open the drain.

• **INJECT**

Inject mode occurs only when a Capillary Interface is installed. In this step, the Interface trap is heated to release the analytes into the GC column.

Inject	0.16 > 0.50
Injector: 100°	
Set: 200°	Method 1
Meth	ALS
Temp	Conf

• **BAKE**

In Bake mode the trap is cleaned for the next run.

Bake	0.30 > 8.00
Trap: 100°	
Set: 225°	Method 1
BGB: OFF	
Meth	ALS
Temp	Conf

### 4.3 Powering Up the System

#### 4.3.1 Running Self Tests

Upon routine power up, the system conducts self tests to confirm that all its heated components are working properly. Default values are loaded into RAM from ROM when either Run or Edit is chosen from the Method menu.

To conduct self tests the system briefly turns on each heater in succession. When the thermocouple for a particular heater registers a temperature increase, the system advances to the next heater.

**Tekmar LSC 2000  
Automatic Concentrator System**

Self Test in Progress

Basic LSC

Line: ok

BOT: ok

Trap: ok

Help

Valve: skipped

Mount: 22<sup>o</sup>

Skip

Self Test in Progress

Capillary Interface

Cryo trap: ok

Injector: ok

Help

Skip

Self Test in Progress

Sample Heater

Sample: 22<sup>o</sup>

Help

Skip

Self tests may be skipped at any time by pressing **F4 (Skip)**. Pressing **F4 (Skip)** will cause the system to advance to the test for the next heater. However, the system responds to skipping a self test in the same

### 4.3.1 Running Self Tests (cont.)

manner that it does a failed self test. Both of these conditions require operator intervention.

#### FAILURE

Basic LSC

Line: ok

BOT: ok

Trap: ok

Help

Valve: skipped

Mount: ok

Ignore

Retest

Press **F3 (Ignore)** to acknowledge that the test was purposefully skipped. If an error message appears for a heater that was not skipped, press **F4 (Retest)** to rerun the self tests on that set of heaters.

**NOTE:** If the accessory modules for a Sample Heater or a Capillary Interface are not installed, the tests for these modules **MUST** be manually skipped.

When the self tests are complete the system goes to the Current Configuration screen:

#### Current Configuration

Date: 11/01/87

Time: 12:30:00

Baud: 1200 ALS 2016: NO

ALS 2032: NO

(PAGE DOWN for more)

Help

LSC

Inst

OK

### 4.3.2 Changing the Viewing Angle of the Screen

The viewing angle of the LCD screen can be adjusted to optimize readability in a variety of unit setup conditions. Press **PAGE UP** to increase the angle of the screen and **PAGE DOWN** to decrease the angle. Press the key down firmly for a continuous change in the angle or press and release the key for an incremental change.

**NOTE:** The viewing angle cannot be adjusted while the unit is in a mode where **PAGE UP** and **PAGE DOWN** provide other functions (for example, while editing the Method Parameters Listing).

### 4.3.3 Loading the Method Default Values Into RAM

Up to four methods can be stored in the memory of the LSC 2000. When powered up, the unit automatically goes to Method 1. (The default values for Method 1 correspond to EPA Method 601.) To go to another Method or to modify the parameter values for a Method, press **F1 (Meth)**. The system asks which Method (1-4) you wish to use. Press the appropriate digit on the keypad. If you wish to run this method, press **F2 (Run)**. If you wish to view or change parameter values, press **F3 (Edit)**.

If this is the initial power up (or if this is a power up after a power failure that resulted in memory loss), the "Parameters Invalid" screen will appear, indicating that by pressing **(Run)** or **(Edit)** you have cued the system to load the parameter default values into Random Access Memory (RAM). Press **F4 (Exit)** to leave the "Parameters Invalid" screen.

If you pressed **F2 (Run)**, the system will go to Start Up mode in the Method you chose. If you pressed **F3 (Edit)**, the system will go to the parameter listing for the Method you chose. To move the cursor use **F3 (->)** or **<- (Backspace)**. To view the next section of the parameters listing (there are 5 "pages"), press **PAGE DOWN**. To change a parameter value, move the cursor to the desired parameter and press **ENTER**. Press the appropriate digits to input the new value and press **ENTER** again. To leave the Method Parameters Listing, press **F4 (Exit)**.

Once these procedures have been accomplished, the system will retain the default or modified Method values in memory (except in certain cases of power failure).

## 4.4 Running a Default Program

The LSC 2000 system includes four default programs, or Methods, that are set according to the standards and procedures established by the United States Environmental Protection Agency. To run a sample using the EPA parameter values already configured into the system, start by using Method 1. When the LSC 2000 is powered up, the introductory screen appears first:

### Tekmar LSC 2000 Automatic Concentrator System

#### 4.4.1 Performing a Run Using Method 1

The system proceeds automatically to the Method 1 program.

<b>Start Up</b>		<b>Method 1</b>	
Line: 80° > 100		Valve: 80° > 100	
BOT: 75° > 100		Capillary	
Mount: 35° > 40		Int: 99° > 100	
<b>Meth</b>	<b>ALS</b>	<b>Temp</b>	<b>Conf</b>

<b>Standby</b>		<b>Method 1</b>	
Trap: 33°		Set: < 30°	
Sample: 21°			
<b>Meth</b>	<b>ALS</b>	<b>Temp</b>	<b>Conf</b>

When the unit has met the parameter values set for Method 1, it goes to Purge Ready and displays the Trap and Sample temperatures. The unit pauses at this point until the operator presses **START** on the keypad.

<b>Purge Ready</b>		<b>Method 1</b>	
Trap: 29°		Sample: 21°	
Ready for sample to be loaded. Press <b>START</b> to begin run			
<b>Meth</b>	<b>ALS</b>	<b>Temp</b>	<b>Conf</b>

4.4.2  
Performing a  
Run Using  
Method 2,3,or 4  
(cont.)

Standby		Method 2	
Trap: 33°		Set: < 30°	
Sample: 21°			
Meth	ALS	Temp	Conf

When the unit has met the parameter values set for Method 2, it goes to Purge Ready and displays the Trap and Sample temperatures. The unit pauses at this point until the operator presses **START** on the keypad.

Purge Ready		Method 2	
Trap: 29°		Sample: 21°	
Ready for sample to be loaded.			
Press START to begin run			
Meth	ALS	Temp	Conf

Only when a sample heater is installed in the system do the Prepurge and Preheat screens appear. If a sample heater is installed, Trap, Sample, and Set temperatures are displayed, as well as a timer for each mode. Time elapse is shown digitally, as well as graphically, with a moving bar display.

Prepurge		3.51 > 4.00	
Trap: 29°			
Sample: 21°		Method 2	
Meth	ALS	Temp	Conf

Preheat		4.53 > 5.00	
Sample: 70°			
Set: 70°		Method 2	
Meth	ALS	Temp	Conf



4.4.2  
 Performing a  
 Run Using  
 Method 2, 3, or 4  
 (cont.)

Purge 0.23 > 12.00  
 Trap: 25° |||||  
 Sample: 70° Method 2  
 Meth ALS Temp Conf

Dry Purge 0.23 > 5.00  
 Trap: 25° |||||||  
 Method 2  
 Meth ALS Temp Conf

Desorb Ready Method 2  
 Waiting for GC ready signal  
 Press STEP if interface is not installed (NI)  
 Meth ALS Temp Conf

Cap Cooldown Method 2  
 Valve: 100° -100° > -120°  
 Set: 100° Injector > Set  
 Meth ALS Temp Conf

Desorb Preheat Method 2  
 79° > 175°  
 Trap > Set  
 Meth ALS Temp Conf

4.4.2  
Performing a  
Run Using  
Method 2, 3, or 4  
(cont.)

Desorb	1.10 > 4.00
Trap: 175°	
Set: 180°	Method 2
Auto Drain: ON	
Meth ALS	Temp D Conf

**NOTE:** The flashing 'D' between (Temperature) and (Configure) on the LCD screen indicates that the drain is open. Press **DRAIN** to close or open the drain.

Inject	0.16 > 0.50
Injector: 100°	
Set: 200°	Method 2
Meth ALS	Temp Conf

Bake	0.30 > 8.00
Trap: 100°	
Set: 225°	Method 2
BGB: OFF	
Meth ALS	Temp Conf

4.4.3  
Interrupting a  
Run

If a run must be interrupted at any time, press **HOLD** on the keypad to cause the unit to pause. Pressing **HOLD** will arrest the run until **AUTO** is pressed. When **AUTO** is pushed the unit will proceed from the point in the procedure where the run was interrupted.

4.4.4  
Aborting a Run

To abort a run, press **STEP TO STANDBY** to terminate a run without undue "wear and tear" to the unit. Since this command terminates the run in progress, a Confirmation screen appears and requests that you press **STEP TO STANDBY** *again* to ensure that accidental termination of a run does not occur.

<b>STEP TO STANDBY</b>	
Current run will be stopped.	
Press <b>STEP TO STANDBY</b> to confirm.	
Help	Continue

**4.4.5  
Reviewing and  
Resetting the  
Clock**

The Clock controls the date and time acknowledged by the system. To view the clock, press **F4 (Conf)** during execution of any program mode. Pressing **F4 (Conf)** from the Start Up screen, for example, will display the Current Configuration screen.

Start Up	Method 1
Line: 80° > 100	Valve: 80° > 100
BOT: 75° > 100	Capillary
Mount: 35° > 40	Int: 99° > 100
Meth ALS	Temp Conf

**F4**

Current Configuration			
Date: 11/01/87	Time: 12:30:00		
Baud: 1200	ALS 2016: NO	ALS 2032: NO	
(PAGE DOWN for more)			
Help	LSC	Inst.	OK

**F2**

**F4**

If the time and date are correct, press **F4 (OK)**. To change them, press **F2 (LSC)** to go to the LSC screen:

Press F2 (Clock) to change time/date Refer to Manual Section 4.4.5 Press F3 (Baud) to change baud rate Refer to Manual Section 4.1.2	Exit
-----------------------------------------------------------------------------------------------------------------------------------------------	------

Set Clock Time & Date Date (mm/dd/yy) : 11/01/87 Time (24 hr format) : 12:30	<-                      ->                      Exit
------------------------------------------------------------------------------------	------------------------------------------------------

Press **F2 (<-)** or **F3 (->)** to select the digit that needs to be changed. Pressing the desired digit on the keypad instantly enters it into system memory. When all values are correct, press **F4 (Exit)**.

**4.4.5  
Reviewing and  
Resetting the  
Clock (cont.)**

**NOTE:** If an invalid key is pressed when attempting to input new time and date values, the message **-> INVALID DIGIT/KEY <-** lights up on the screen and the system beeps. When the message disappears you may reattempt to enter the new values.

**4.4.6  
Reviewing and  
Changing  
Instrument  
Configuration**

To review which instruments are configured into the system, press **F4 (Configure)** during execution of any program mode. Pressing **F4 (Configure)** from the Start Up screen, for example, will display the Current Configuration screen.

Start Up	Method 1
Line: 80° > 100	Valve: 80° > 100
BOT: 75° > 100	Capillary
Mount: 35° > 40	Int: 99° > 100
Meth ALS	Temp Conf

Current Configuration	V1.3E
Date: 8/01/88	Time: 12:30:00
Baud: 1200	ALS 2016: N ALS 2032: N
(PAGE DOWN for more)	
Help LSC	Inst. OK

Press **PAGE DOWN** on the keypad to see the rest of the Instrument Configuration listing of accessories:

2016 Heater: NO	2032 Htr: NO
Capillary Interface: NO	
Sample Heater: NO	
Aux. Heater: NO	
(PAGE UP for more)	
Help LSC	Inst. OK

If an instrument needs to be configured differently from the way it appears in the listing, press **F3 (Inst.)** to access the Instrument screen:

**4.4.6  
Reviewing and  
Changing  
Instrument  
Configuration  
(cont.)**

```

ALS 2016:
2016 Heater: not installed
ALS 2032:
2032 Heater: not installed
(PAGE DOWN for more)
Help      <-      ->      Exit
    
```

To change an instrument's configuration, press **F2 (<-)** or **F3 (->)** to move the highlighted box to the desired instrument. With the desired instrument highlighted, press **Y (digit 7)** or **N (digit 9)** to reconfigure the system to acknowledge the instrument. Press **PAGE DOWN** to access additional instruments in the listing:

```

Auto Proc Sampler:    not installed
Capillary Interface:  N
Sample Heater:        N
Aux. Heater:          N
(PAGE UP for more)
Help      <-      ->      Exit
    
```

**NOTE:** If an accessory is not installed it cannot be turned on (activated).

To turn an accessory on or off, press **F2 (<-)** or **F3 (->)** to move the highlighted box to the desired instrument. With the desired instrument highlighted, press **Y (digit 7)** or **N (digit 9)** to activate or deactivate the instrument. When all instruments are configured as desired, press **F4 (Exit)** to return to the Current Configuration screen.

```

Current Configuration      V1.3E
Date: 8/01/88      Time: 12:30:00
Baud: 1200      ALS 2016: NO      ALS 2032: NO
(PAGE DOWN for more)
Help      LSC      Inst.      OK
    
```

Press **F4 (OK)** to return to Program mode.

#### 4.4.7 Reviewing Parameter Temperature Values

For quick review of temperature and time parameter values assigned to a given Method, press **F3 (Temp)** from any Program mode screen.

**NOTE:** No changes can be made to Parameter Values from the Temperature menu. To modify Parameter Values, see Section 4.5.1.

Press **F3 (Temp)** from, for example, the Start Up screen to display the Temperature Zone screen:

<b>Start Up</b>		<b>Method 1</b>	
Line: 80° > 100		Valve: 80° > 100	
BOT: 75° > 100		Capillary	
Mount: 35° > 40		Interface: 99° > 100	
Meth ALS		Temp Conf	

Line: 100° > 100	Valve: 99° > 100
BOT: 100° > 100	Mount: 100° > 100
Trap: 21°	
(PAGE DOWN for more)	

**Exit**

<b>Capillary Interface</b>	
Cryo Trap: 100° > 100°	
Injector: 21°	
(PAGE UP/PAGE DOWN for more)	

**Exit**

<b>Sample Heater</b>	
Sample:	21°
<b>Aux. Heater</b>	
Aux Htr:	21°
(PAGE UP/PAGE DOWN for more)	

**Exit**

**NOTE:** If no Capillary Interface or Sample Heater is installed the screen displays "not installed" where the set temps. are normally located. Press **F4 (Exit)** to return to the Introductory screen.

## 4.5 Modifying a Program

### 4.5.1 Setting New Values for Method Parameters

The system offers four programmable Methods with which to run a sample. If you wish to modify default values that are already programmed into the system, first power up the unit.

**NOTE:** Once the new values have been entered in the system, they will remain there until changed again (unless they are altered by power failure.) This programmable feature allows for four permanent sets of Parameter Values with which to run a sample.

When the system is powered up, the Introductory screen appears:

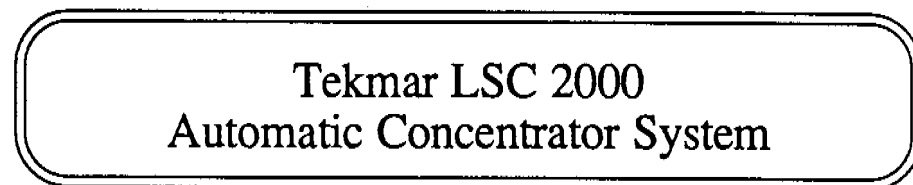

The system performs self tests and then proceeds automatically to the Method 1 program.

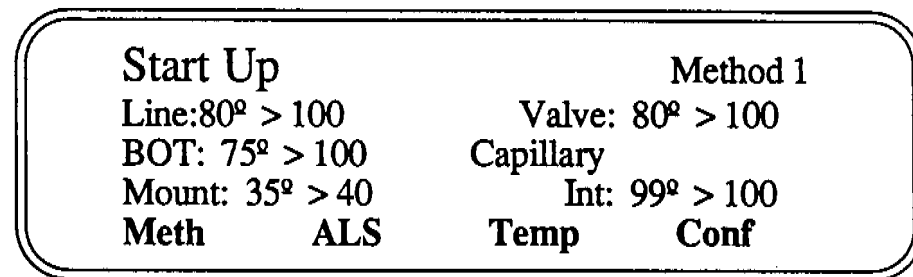

To modify the parameter values for Method 1, press **F1 (Method)**.

**NOTE:** Method Parameter values can be modified for any Method from any Program mode screen. However, if modifications are made from any mode other than Start Up, Standby or Purge Ready, the sample cannot be run immediately with the new parameter values.

### 4.5.1 Setting New Values for Method Parameters (cont.)

Method 1 active.  
Select Method 1, 2, 3, or 4  
Refer to Manual Section 4.5.1  
**Exit**

Enter the number of the Method you wish to use.

Method 1 selected.  
Now select action: Run or Edit  
**Help      Run      Edit      Exit**

Press **F3 (Edit)** to change the parameter values for the selected method. If you need help in choosing parameter values for a method, refer to Section 5.7, "Selecting Operating Parameters."

**NOTE:** Changes in the Valve, Line, Mount, ALS Valves, or Capillary Interface parameter values will take effect on the next run. All other parameter times and temperatures will take effect immediately.

**Method 1 Parameters**  
Standby: 30<sup>o</sup>                      Prepurge: -NI-  
Preheat: -NI-                      Sample: -NI-  
Purge: 12.00                      Dry Purge: 6.00  
(PAGE DOWN for more)  
**Help                                      ->      Exit**

Cap Cooldown: -120<sup>o</sup>  
Desorb Preheat: 100<sup>o</sup>  
Desorb: 4.00 min. at 180<sup>o</sup>  
Inject: 0.50 min at 200<sup>o</sup>  
(PAGE UP/PAGE DOWN for more)  
**Help                                      ->      Exit**



4.5.1  
Setting New  
Values for  
Method  
Parameters  
(cont.)

Bake: 8.00 min at 225°  
Auto Drain: OFF  
Bake Gas Bypass: OFF  
(PAGE UP/PAGE DOWN for more)  
Help -> Exit

Valve: 50\* Line: 50\*  
Mount: 40\* Aux line: -NI-  
2016 Valve: 100° Line: 100°  
2032 Valve: 100° Line: 100°  
(PAGE UP/PAGE DOWN for more)  
Help -> Exit

Capillary Interface: 100°  
Runs per sample: 1  
(PAGE UP for more)  
Help -> Exit

Press F3 (->) to place the highlighted box on the parameter you wish to change. (The system automatically highlights the first value of each parameter on a screen.) If you don't see the parameter you want on the screen, press **PAGE DOWN** or **PAGE UP** to view the other Method parameters.

**NOTE:** The system will beep if **PAGE DOWN/PAGE UP** is pushed at the first or last screen of the Method Parameters "page."

With the desired parameter highlighted, press **ENTER** to see that specific parameter's settings screen. For example, with the highlighted box on the set temperature for Standby mode, press **ENTER**.

Current: 30°  
Minimum: 0° Maximum: 100°  
Standby: \_\_\_  
(Press ENTER for no change)

### 4.5.1 Setting New Values for Method Parameters (cont.)

The settings screen for the selected parameter value appears. The settings screen displays:

- 1) the current value setting
- 2) the value range available

To change the current value, press the digits on the keyboard, inputting the new value. (If you press the wrong digit use <- (**BACKSPACE**) to erase it.) Press **ENTER** to fix the new setting into system memory. Repeat this procedure for each of the parameter values within this Method that are to be changed. When all parameter values are correct, press **F4 (Exit)** to return to the Program mode. If a run was being performed while the Method Parameters were being changed, the system will go to the Program mode screen in effect.

Pressing **F4 (Exit)** also enables you to set new parameter values for one of the other three Methods. Refer to the beginning of Section 4.5.1 to set new Parameter values for other Methods.

***NOTE:*** Valve, Line and Mount temperature changes will take effect on the following run. Other parameter values will "kick in" immediately.

### 4.5.2 Using **STEP TO STANDBY**

The Step To Standby feature allows instant termination of a run without undue "wear and tear" to the unit. When **STEP TO STANDBY** is pressed, the system goes directly to Standby mode from whichever mode it is performing when **STEP TO STANDBY** is pressed. Since this command terminates the run in progress, a Confirmation screen appears:

**STEP TO STANDBY**  
Current run will be aborted  
Press **STEP TO STANDBY** to confirm  
**HELP** **CONTINUE**

**4.5.2  
Using STEP TO  
STANDBY (cont.)**

Pressing **STEP TO STANDBY** again confirms that you really want to abort the run. This feature avoids accidental termination of a run due to an inadvertent keystroke.

**4.5.3  
Using STEP TO  
BAKE**

The Step To Bake feature accommodates quick conditioning of new traps, or immediate cleaning of a previously-used trap to prepare it for a new run. Pressing **STEP TO BAKE** causes the system to go directly to Bake mode from whichever mode it is performing when Step To Bake is pressed.

**4.5.4  
Activating Auto  
Drain**

To activate or deactivate Auto Drain for a specific Method, refer to Section 4.5.1 to first obtain the Method 1, 2, 3, or 4 Parameters Listing. Press **PAGE DOWN** until the screen beginning with the values for Bake mode appears:

Bake: 8.00 min. at 225°  
Auto Drain: OFF  
Bake Gas Bypass: OFF  
(PAGE UP/ PAGE DOWN for more)  
Help      Run      ->      Exit

Press **F3 (->)** to place the highlighted box on the response for Auto Drain. Press **ENTER** to see the Auto Drain settings screen.

Current: OFF  
Auto Drain: Choose ON/OFF  
ON    OFF                      Exit

Press **F1 (ON)** or **F2 (OFF)** to activate or deactivate the Auto Drain feature. Selecting ON/OFF automatically changes the selection and takes the user back to the Method Parameter Listing. Press **F4 (Exit)** to return to the Method Parameter listing without changing the Auto Drain selection.

### 4.5.5 Activating Bake Gas Bypass

To activate or deactivate Bake Gas Bypass for a specific Method, refer to Section 4.5.1 to obtain the Method 1, 2, 3, or 4 Parameters Listing. Press **PAGE DOWN** until the screen beginning with the values for Bake mode appears:

```

Bake: 8.00 min. at 225°
Auto Drain: OFF
Bake Gas Bypass: OFF
(PAGE UP/PAGE DOWN for more)
Help                ->  Exit
  
```

Press **F3 (->)** to place the highlighted box on the response for Bake Gas Bypass. Press **ENTER** to see the Bake Gas Bypass settings screen.

```

Current: OFF
Bake Gas Bypass: Choose ON/OFF
ON  OFF                Exit
  
```

Press **F1 (ON)** or **F2 (OFF)** to activate or deactivate the Bake Gas Bypass feature. Selecting ON/OFF automatically changes the selection and takes the user back to the Method Parameter Listing. Press **F4 (Exit)** to return to the Method Parameter listing.

### 4.6 System Faults and Failure

System failure can be caused by any unusual circumstance such as power shortage, power outage, operator error, etc. Normally, the battery backup will save data stored in the memory of the microprocessor in the event of a power failure. Depending on where the unit was in the sample run process when the system failure occurred, different means of restarting the system will apply.

## 4.6 System Faults and Failure (cont.)

If the program detects a parameter error (an invalid or out-of-range value) or if default values are being loaded into RAM (upon initial power up) when **F2 (Run)** or **F3 (Edit)** is chosen from the Method menu, the following screen will appear:

Method 2 Parameters INVALID.  
Will set to default values.  
Refer to Manual Section 4.6.1

**Exit**

### 4.6.1 Interpreting Invalid Input

The system is set to accept a specific range of values that are acceptable under EPA guidelines. Each program mode value range is as follows:

Standby:	0-100°C
Prepurge:	0-99.9 min.
Sample:	0-200°C
Preheat:	0-99.99 min.
Purge:	0-99.99 min.
Dry Purge:	0-99.99 min.
Cap Cooldown:	-150° to +40°C
Desorb Preheat:	0-400°C
Desorb:	0-99.99 min. at 0-400°C
Inject:	0-99.99 min. at 0-300°C
Bake:	0-99.99 min. at 0-400°C
Mount:	0-200°C
Valve:	0-300°C
Line:	0-300°C

**NOTE:** If a Capillary Interface is not installed, the values for Cap Cooldown and Inject will read **-NI-** (not installed). If a Sample Heater is not installed, the values for Prepurge, Preheat, and Sample will read **-NI-** (not installed).

## 4.6.2 Restarting After Power Loss

When powering up the system after power loss, operating parameters that had previously been stored in RAM may need to be re-entered. It may also be necessary to re-enter parameter values if a line transient has altered or erased the program parameters stored in RAM.

**NOTE:** Keep a hard copy of parameter values used in each Method so that you will have a record of them if a power failure occurs and the values need to be re-entered.

Power failure can cause the system to display one of three "POWER FAIL" screens. "POWER FAIL" screens indicate that the operator may be required to reset parameter values and/or system configuration.

POWER FAIL  
Memory lost -- Reset clock  
Exit

POWER FAIL  
Power fail during cycle  
Exit

POWER FAIL  
Error -- program restarting  
Exit

Press **F4 (Exit)** to return to the Introductory screen.

Tekmar LSC 2000  
Automatic Concentrator System

**4.6.2  
Restarting After  
Power Loss  
(cont.)**

**NOTE:** If power down occurs during Standby or Purge Ready mode, no Power Fail screen will be displayed. The system will proceed on its own to the Introductory screen.

If the Method being used before power failure contained modified parameter values (values other than the system's default values), these values may need to be re-entered. See Section 4.4.7 first to review the parameter temperature values. If the parameter values do need to be modified, see Section 4.5.1 for guidance in setting new values for Method parameters. The system clock may also need to be reset after a power failure. See Section 4.4.5 for assistance with reviewing and changing the clock.

**4.6.3  
Running  
Self Tests**

After power failure, servicing, or whenever the unit is powered up, the system conducts self tests to confirm that all its heated components are working properly. To conduct self tests the system briefly turns on each heater in succession. When the thermocouple for a particular heater registers a temperature increase, the system advances to the next heater.

**Tekmar LSC 2000  
Automatic Concentrator System**

Self Test in Progress

Basic LSC

Line: ok

Valve: skipped

BOT: ok

Mount: 22<sup>o</sup>

Trap: ok

Help

**Skip**

### 4.6.3 Running Self Tests (cont.)

Self Test in Progress  
Capillary Interface  
Cryo trap: skipped  
Injector: 0°  
Help

Skip

Self Test in Progress  
Sample Heater  
Sample: 22°  
Help

Skip

Self tests may be skipped at any time by pressing **F4 (Skip)**. Pressing **F4 (Skip)** will cause the system to advance to the test for the next heater. However, the system responds to skipping a self test in the same manner that it does a failed self test. Both of these conditions require operator intervention.

**FAILURE**

Basic LSC

Line: ok

Valve: skipped

BOT: ok

Mount: ok

Trap: ok

Help

Ignore

Retest

Press **F3 (Ignore)** to acknowledge that the test was purposefully skipped. If an error message appears for a heater that was not skipped, press **F4 (Retest)** to rerun the self tests on that set of heaters.

**NOTE:** If the accessory modules for a Sample Heater or a Capillary Interface are not installed, the tests for these modules **MUST** be manually skipped.

When the self tests are complete the system goes to the Current Configuration screen.





1



*SECTION 5*  
*ROUTINE OPERATING PROCEDURES*

---



## 5.1 Preparing Blank Water

Blank water (reagent water or organic-free water) is defined as water that is free of interferences when run by purge and trap analysis. Obtaining blank water can be difficult. Some water purifiers (e.g., Millipore Super Q) can provide accessible quality blank water when freshly charged. However, blank water is more commonly prepared by one of two methods.

- 1) Pass distilled water through a bed of activated carbon at least 12" deep. Allow the water to flow from bottom to top by setting the column up to siphon by placing the supply vessel high and the collection vessel low, or
- 2) Boil the water and then purge it while at 80-90° with helium or nitrogen for at least one hour.

With either method the blank water must be used immediately. Always examine the water before use by analyzing it without any added standards.

## 5.2 Preparing a Standard

Preparing proper standards is the key to accurate quantitation. Using a concentrator usually means that the concentration of the analytes is low, so low level standards must be made. Small errors that occur in high level standards are usually insignificant, but the same error in a low level standard can mean a large percentage of error. For this reason, special care must be taken in preparing, using, and especially, in storing the standard. While many commercial standards are available, and most are of high quality, they are of limited usefulness. Either the mixes do not include all of the desired analytes, or extra analytes are present, or the concentration may be off. Also, they are expensive and the EPA does not allow their use. For these reasons, we recommend preparing your own standards.

There are many different ways to prepare your own standards. For water samples it is common to prepare methanol solutions containing known amounts of the

## 5.2 Preparing a Standard (cont.)

compounds of interest. These compounds cannot be prepared directly in water due to their insoluble nature and the instability of aqueous standards. The EPA-recommended procedure is as follows:

- 1) Fill a 10ml volumetric flask with about 9.8ml methanol.
- 2) Allow the flask to stand unstoppered until all alcohol wetted surfaces have dried.
- 3) Weigh accurately to the nearest 0.1 mg.  
*NOTE:* All weighings are critical!
- 4) Using a 100  $\mu$ l syringe, immediately add 2 drops of neat standard (minimum 97% purity) to the flask, then reweigh. Be sure that the drops fall directly into the methanol without making contact with the neck of the flask.
- 5) Dilute to volume, place the stopper on the flask, and mix by inverting the flask several times.
- 6) Calculate the concentration in micrograms per milliliter from the net gain in weight.
- 7) Transfer the solution to a 10ml screwcap bottle with a Teflon cap liner.
- 8) Store at 6°C.

These solutions are stable up to 4 weeks except for solutions containing 2-chloroethylvinyl ether, which are stable for only one week. Dilutions in methanol can be made to provide a range of standards. Aqueous standards are prepared by spiking the standard into a 100ml volumetric flask filled with blank water. Do not inject more than 20ml of methanol into 100ml of water.

## 5.3 Loading a Sample

When loading aqueous samples through the sample valve with a syringe, turn the arrow on the valve stem so that it points toward the syringe to load a sample, and pointing to the left at all other times. Remove the plunger from the syringe barrel. Carefully pour the sample into the barrel until the sample overflows. Insert the plunger and adjust to the desired volume. Be sure to vent any residual air while adjusting the volume.

3  
Loading a  
Sample (cont.)

Samples can be loaded in 2 ways:

- 1) Remove the glassware, insert the sample, and reinstall the glassware, or
- 2) Use a luer-lock syringe to load the sample through the sample valve.

Solids are generally weighed in the glassware, while liquids are usually loaded from a syringe.

**NOTE:** Loading through the sample valve should be performed only with aqueous samples.

**CAUTION:** *When loading a solid sample make sure that Auto Drain is turned OFF or the unit will be damaged.*

Sample Size

Choosing sample size depends on many factors including:

- physical state
- homogeneity
- concentration and vapor pressure of target compounds
- type of detector used
- desired detection limits
- type of GC column

Larger samples can provide increased sensitivity, although they can also overload columns and saturate detectors. A good rule of thumb for samples of unknown concentrations is to start small (e.g., 25mg solids, 0.5ml liquids) and increase as needed. It is generally easier to optimize results by increasing the sample size rather than decreasing it. Bear in mind that:

- 1) Capillary columns require small samples or split injection to avoid column overloading.
- 2) Sensitive detectors (e.g., electron capture) require small samples to avoid saturation.
- 3) Compounds of low concentration or volatility require larger samples to achieve sufficient sensitivity.

## *ROUTINE OPERATING PROCEDURES*

### **5.4 Loading a Standard**

Standards are loaded in the same way samples are loaded. Aqueous standards should be prepared immediately before analysis. Standards can be spiked from stock solutions of the sample compounds in a water-soluble solvent (e.g., methanol, acetone). Spiking can be performed by inserting the needle of a microliter syringe into the luer fitting of the sample syringe.

### **5.5 Quantitating a Run**

Quantitation can be accomplished several ways, depending on the type of information required of the sample. For many samples, however, this may not be possible (e.g., outgassing compounds from solids). Quantitation in this case relies on a 3-run purging of the sample. The amount recovered from the first two runs can now be used to calculate the purge efficiency of the first run, resulting in a number which can be used for subsequent samples.

### **5.6 Using Blanks**

An instrument blank (i.e., purging a clean, empty sampler) is required to ensure that the purge gas supply is clean and that previous samples have not contaminated the instrument. The number and type of blanks required depends upon the samples run. If any solvents are used they must be run to determine the possible presence of contaminants. Bear in mind that the LSC 2000 is a concentrating system, therefore its purity and cleanliness requirements are more stringent than for any other instrument technique.

5.7  
Selecting  
Operating  
Parameters

The values selected for each different operating parameter depend heavily upon the nature of the sample and the type of information desired. This section discusses typical parameter selections and the results that can be expected for different values.

**PREPURGE Time**

Prepurge is functional only when a sample heater is installed. It enables the purge gas to be turned on before heating the sample. This serves to displace all oxygen from the glassware before heating. This eliminates the possibility of any heat-induced oxidation occurring in the sample. Prepurge is normally used only with flavor or fragrance samples. The time should be chosen so that the total volume of prepurge gas equals about three times the glassware volume. The total volume of a 5ml sparger is about 11ml, a 25ml sparger about 34ml. If the purge flow rate is 50ml/min., for example, set the prepurge time to 0.7min for a 5ml sparger, 2.1 min. for a 25ml sparger.

**PREHEAT Time**

Preheat is functional only when a sample heater is installed. It allows the sample to be equilibrated at its temperature set point before beginning to purge. This maximizes quantitative reproducibility. The sample heats at about 25°/min. For every 25° above ambient allow one minute preheat time. If not performing quantitative analysis, time can be saved by shortening or eliminating this step.

**COOLDOWN Temperature**

Cooldown is functional only when a Capillary Interface is installed. It is the temperature at which the sample will be cryofocused. This setpoint varies significantly depending upon the lightest compound analyzed, the column diameter, film thickness, flow rate, and whether a precolumn is used. Typical values range from -150° to -70°. Consumption of liquid nitrogen approximately doubles for every 20° drop in



**5.7  
Selecting  
Operating  
Parameters  
(cont.)**

setpoint. Set the temperature to the highest value at which peak shapes are still good.

**INJECT Temperature and Time**

Inject is functional only when a Capillary Interface is installed. The temperature chosen must be high enough to drive the least volatile component out of the cryofocusing area, yet not so high as to break down either the stationary phase or the polyimide outer coating of the column. Set the temperature to the same value as the final temperature of the oven temperature program. The time chosen must be long enough to allow the cryotrap sufficient time to reach the temperature setpoint. This cryotrap heats at approximately 800°/min. Since longer times are not at all damaging, add at least 0.25 min. longer than necessary to reach the set point. Typical values are 0.50 to 1.00 min.

**AUTO DRAIN**

AUTO DRAIN empties the purge vessel during DESORB. Note that AUTO DRAIN should be used only with water samples free of particulates. These particulates could clog the drain system.

**BAKE GAS BYPASS**

BAKE GAS BYPASS allows the gas used to clean the trap in BAKE to bypass the purge vessel. Normally this gas passes through the glassware, but if the sample has not been drained it could cause additional volatiles to be purged, thus hindering total cleanup of the trap. Normally if AUTO DRAIN is on then BAKE GAS BYPASS is off, and vice versa.

**VALVE and LINE Temperatures**

**CAPILLARY INTERFACE Temperature**

The 6-port valve and sample lines of the LSC 2000 and accessories are heated to prevent cross-contamination of samples due to memory effects. These temperatures should be set high enough to prevent this, however, not so high as to cause any

7  
**Selecting  
 Operating  
 Parameters  
 (cont.)**

degradation of labile compounds. These values are normally set to 100°C as a minimum. If the sample is heated, the valve and lines should be set at least as high as the sample temperature. In cases where contamination does occur, these values can be raised to accelerate cleanup.

**Mount Temperature**

The sampler mount is heated to prevent memory effects. However, it does not need to be turned on always, and may occasionally even have an adverse effect on samples by heating the upper part of the glassware. This heat may be conducted to the sample. For water or soil samples the mount need never be heated. In fact, a cool mount allows excess water vapor to condense and fall back into the glassware. For certain types of heated samples (esp. oils) the mount must be heated to prevent memory effects. Set the mount temperature equivalent to the sample temperature.

**CAUTION:** When the mount is heated the sampler mounting nut will be **HOT**. Take care when changing glassware.

**PURGE Time**

The purge time should be chosen with the goal of good sensitivity and reproducibility in mind. Times longer than 15 minutes generally have few benefits, and can lead to breakthrough of the trap. A good starting point is 10 minutes.

**DRY PURGE Time**

The dry purge time should be about 4 to 6 minutes, depending on the purge flow rate. Allow enough time for 200 to 250ml of gas to pass through the trap.

**Purge Flow Rate**

The purge flow rate is normally 40ml/min. Faster flow rates can affect trapping efficiency. Using larger diameter traps (e.g. 1/4") can allow faster flow

**5.7  
Selecting  
Operating  
Parameters  
(cont.)**

rates due to decreased linear flow velocity. Slower rates can be beneficial in minimizing foaming or aerosol problems. The flow rate can be measured by attaching a bubble flowmeter or other flow indicator to the vent port located on the front panel of the LSC 2000. (We recommend use of the Tekmar Digital Flow Meter, #13-0079-000.)

**PURGE READY Temperature**

Purge Ready should be set about 30°C. This ensures good trapping efficiency. Higher settings may be necessary if the ambient temperature makes achieving this difficult.

**DESORB PREHEAT Temperature**

Desorb preheat is intended to help deliver the sample to the GC in the tightest slug possible. The desorb preheat temperature should be set to 5°C below the DESORB temperature.

**DESORB Temperature and Time**

The desorb temperature is normally between 150° and 200°C. The exact temperature depends on the sample compounds. For volatile compounds purged from ambient samples, 150°C is good. For higher temperature samples, the desorb temperature must be raised to quickly desorb the less volatile compounds. The desorb time is normally four minutes. This works equally well for flow rates from 2 to 50ml/min. This time is also sufficient for capillary column flow rates when the flow rate is set by pressure control. Mass flow control usually requires longer times of up to 8 minutes.

**BAKE Temperature and Time**

The bake temperature is normally 225°C. Higher temperatures do not increase the bake efficiency, and can lead to shorter absorbent lifetimes. The bake time is normally 7 to 10 minutes. For heavily loaded traps, or compounds of low volatility, longer times (up to 20 minutes) may be required.

ROUTINE OPERATING PROCEDURES

**7.1  
Parameters for  
EPA  
Procedures**

EPA procedures specify values for each parameter.  
These values are listed below for each method.

Method	<u>501.1</u>	<u>502.1/601</u>	<u>503.1/602</u>	<u>624</u>
Sample Size	5ml	5ml	5ml	5ml
Purge Time	11 min.	11 min.	12 min.	12 min.
Dry Purge Time	Off	Off	6 min.	Off
Purge Flow	40ml/min	40ml/min	40ml/min	40ml/min
Desorb Time	4 min.	4 min.	4 min.	4 min.
Desorb Temp.	180°C	180°C	180°C	180°C
Bake Time	NS*	7 min.	7 min.	7 min.
Bake Temp.	NS*	180°C	180°C	180°C
Trap Mat'l **	T	T/SG/C	T	T/SG

\*NS= not specified

\*\*T= Tenax, SG= Silica Gel, C= Charcoal

These are the purge and trap parameters specified in various EPA drinking water and municipal and industrial waste water methods. They are listed as a quick reference for customers doing analyses under EPA certification. Different applications or instrumental configurations may be optimized by varying these parameter settings.



**SECTION 6**  
**GENERAL MAINTENANCE**

---



## 6.1 Changing the Trap

### New Installations

The LSC 2000 is delivered with a blank trap installed. This prevents the damage that would be done to a packed trap if the unit was powered up with no purge gas flow present. **Replace the blank trap with a packed trap before running a sample.**

### How to change a trap

- 1) Remove the trap door at the front end of the left panel.
- 2) **Make sure the trap is not hot.**
- 3) If you have already powered up the unit, make sure the system is in Purge Ready or Standby.
- 4) Make sure the unit is in HOLD, not AUTO.
- 5) Loosen the nut at the top of the trap one full turn but do not remove it completely.

**NOTE:** The nut at the top of the trap should have been fastened finger tight and loosened easily. If not, the ferrule may need to be replaced.

- 6) Hold the bottom fitting in place with a 7/16" wrench while using a 7/16" wrench to turn the nut at the bottom of the trap counter-clockwise until the fitting is disengaged.
- 7) Grasp the trap furnace and trap and pull the trap straight down and out of the upper trap fitting.
- 8) Grasp the trap furnace in one hand and the lower trap fitting with the other hand and pull the trap out of the furnace.
- 9) Slide a packed trap into the trap furnace sleeve.
- 10) Reconnect the top and bottom fittings. Take care not to tighten the top fitting past finger tight. Doing so may result in damage to the teflon ferrule.
- 11) While holding the fitting in place with a 7/16" wrench, tighten the brass nut at the bottom with another 7/16" wrench 1/8 turn past finger tight.
- 12) Put the trap door back on.

Before samples can be run, the new trap must be thermally conditioned. Refer to Conditioning a New Trap, Section 6.2.



## 6.1 Changing the Trap (cont.)

### When to replace a packed trap

Tenax has a significantly shorter lifetime than do silica gel or charcoal. Silica gel and charcoal normally do not affect trap longevity. Trap lifetimes range from 2 weeks to 5 years, with the average being approximately 6 months.

### *Indicators of trap age are:*

- 1) Increase in background. This usually takes the form of benzene and other aromatics in instrument blanks.
- 2) Losses of brominated compounds while other compounds remain constant.
- 3) Increase in backpressure.

## 6.2 Conditioning a New Trap

To condition a trap, first make sure you have followed the procedures for powering up the unit (if not, see Powering Up the System, Section 4.3). These procedures include those which load the Method default values into the Random Access Memory (RAM) of the microprocessor. These defaults include a value of 225°C for the Bake mode. Press **STEP TO BAKE** to cause the system to go to Bake mode. Press **HOLD** to keep the unit in Bake mode for at least 10 minutes to thermally condition the trap.

Tenax requires only a short conditioning period, about 10 minutes at 225°C. Silica gel and charcoal require about the same conditions. For heavily loaded traps or compounds of low volatility, longer bake times may be required. If a trap is contaminated by a dirty sample, overnight conditioning may be necessary.

Temperatures above 225°C do not speed up conditioning and may shorten trap lifetime. A 10-minute conditioning period at the start of each day is recommended if organic solvents are present in the ambient atmosphere.

### 6.3 Cleaning the Sample Lines

The LSC 2000 can become seriously contaminated from a heavily contaminated sample or from poor quality purge gas.

For sample-caused contamination, turn Bake Gas Bypass off and install clean, dry glassware. Press **STEP TO BAKE** and then press **HOLD**. Keep the unit in Bake mode for at least 1 hour. In some cases longer durations might be required.

If contamination is due to poor quality purge gas, first replace the tank *and all hydrocarbon traps on the gas supply line*. This process may be sufficient to obtain good blanks. If not, press **STEP TO BAKE** and then press **HOLD**. Keep the unit in Bake mode for at least 1 hour. In some cases longer times might be required. If the contamination problem persists, call Tekmar's Applications Department for assistance.

### 6.4 Cleaning Glassware

Clean glassware is essential to interference-free runs. This applies to flasks and cylinders as well as samplers, i.e., any vessel used to handle samples, standards, blank water, etc. To effectively clean glassware, Tekmar recommends:

- 1) Using dedicated glassware,
- 2) obtaining an ultrasonic bath, and
- 3) obtaining a muffle furnace.

Dedicated glassware refers to glassware that is used for concentrator work *only*. Glassware that is used for other procedures such as extractions, often is not clean enough to use in trace applications.

An ultrasonic bath is a godsend for saving time. Rather than laboriously scrubbing samplers, a cursory scrubbing followed by ultrasonics is far more effective and much less labor intensive. Ultrasonic baths can effectively clean the frits and walls of frit samplers that brushes cannot reach. Any of the glassware detergents recommended for use with an ultrasonic bath are acceptable. (We recommend use of the Tekmar Ultrasonic Bath, #13-0081-000).

**6.4  
Cleaning  
Glassware  
(cont.)**

A muffle furnace is excellent for cleaning many samplers that nothing else can touch. Set the temperature to approximately 350-400°C (do not go too high, the glassware may melt) and allow the residues to be oxidized. After the glassware has cooled, the remaining char is easily removed with a brush and a cleaning agent. (We recommend the Tekmar Muffle Furnace, #13-0080-000.)

The sample needle should also be cleaned on a routine basis. Frequency of cleaning depends on the nature of the sample. Aqueous samples require infrequent cleaning while oils and other messy samples require cleaning after every run.

**6.5  
Ordering  
Replacement  
Parts**

Tekmar's factory service facilities are located in Cincinnati, Ohio and may be contacted by calling toll free (800) 543-4461, or in Ohio, (800) 344-8569. Our Service Department experts can help locate the cause of a problem and can determine the best way to expedite repair. All replacement parts for the LSC 2000 are described in this section. Please include the model and serial number of your instrument when ordering spare parts.

**SAMPLE HANDLING**

14-2337-024	5ml Fritted Sparger (glassware only)
14-2334-024	25ml Fritted Sparger (glassware only)
14-2336-024	5ml Needle Sparger (glassware only)
14-2333-024	25ml Needle Sparger (glassware only)
14-3096-000	5ml Fritted Sparge Kit
14-3095-000	25ml Fritted Sparge Kit
14-3094-000	5ml Needle Sparge Kit
14-3093-000	25ml Needle Sparge Kit
14-1101-050	Sample Valve, 3-Port Assembly
14-0216-016	Female Luer Connector for Sample Valve
14-3367-002	Drain Line Assembly
14-2988-000	Purge Line Assembly

## 6.5 Ordering Replacement Parts (cont.)

### SAMPLE HANDLING (cont.)

14-3097-016	Ferrule, 1/16" Valco, Teflon (for sample fitting)
14-3181-016	Sample Nut, Valco, 1/2"
14-3124-016	Short nut, 1/16" (for sample needle)
14-3123-016	Ferrule, 1/16", ETFE (for sample needle)
14-3126-053	Needle, 5ml, 8-5/8"
14-3127-053	Needle, 25ml, 10.25"
14-1590-016	Plug nut, 1/16", SS

### SYRINGES

14-0069-052	5ml Sample Syringe w/Luer Connector
14-0070-052	25ml Sample Syringe w/Luer Connector
12-0089-052	10ul Calibration Syringe

### FITTINGS

14-3145-000	Sample Mount Wrench
14-2389-016	Sample Fitting Tee
14-0264-016	Union, Bulkhead, 1/16", SS
14-0356-016	Union, Bulkhead, 1/8", Filter Assembly
12-0064-016	Union, 1/8"-1/8" Stub, Brass, Bulkhead
14-2401-016	Top Trap Fitting, 1/8", Gold-plated
14-2517-016	Top Trap Fitting, 1/4", Gold-plated
14-2628-016	Tee, 1/16", Gold-plated, dry purge
14-0243-016	Nut, Short, for 1/16" tube, Valco
14-0159-016	Nut, 1/16", SS, Swagelok
14-2931-016	Ferrule, 1/16", graphite/vespel
14-0051-016	Union, 1/16", SS
12-0042-016	Union, 1/16"-1/8", Stub, Brass
12-0073-016	Union, 1/8", Brass
12-0070-016	Tee, 1/8", Brass
14-3098-016	Ferrule, 1/2" Valco, Teflon
14-0521-016	Ferrule, 0.4mm I.D., graphite/vespel
14-0540-016	Ferrule, 0.5mm I.D., graphite/vespel
14-2074-016	Ferrule, 0.8mm I.D., graphite/vespel
14-0442-016	Ferrule set, 1/16", Swagelok, Teflon

## GENERAL MAINTENANCE

### 6.5 Ordering Replacement Parts (cont.)

#### TUBING

14-0546-002	Tubing, 1/8", Copper (price/ft., min. 5 ft.)
14-0441-002	Tubing, 1/16", Nickel, Large Bore (price/ft., min. 5 ft.)
14-2922-002	Tubing, 1/16", Glass-Lined (price/ft., min. 5 ft.)
14-2925-002	Top of Trap Glass Line Assembly
14-2926-002	Sample Glass Line Assembly
14-2927-002	6-Port Glass Line Assembly
14-0539-002	Tubing, Fused Silica, 0.32mm I.D., (price/meter)
14-2072-002	Tubing, Fused Silica, 0.53mm I.D., (price/meter)
14-3125-002	Hypodermic Tubing, SS, 16GA (price/foot)
14-3227-002	Transfer Glass Line Assembly

#### ELECTRONICS

14-2984-000	Microprocessor Buzzer
14-2884-000	Microprocessor Cable
14-2406-000	Front Panel Keypad
14-2522-000	CPU Board Microprocessor w/ROM
14-2983-000	CPU Board Microprocessor w/o ROM
14-2982-000	ROM for CPU Board
14-2575-000	Power Supply Board (110V)
14-3326-000	Power Supply Board (220V)
14-2576-000	Interface Board
14-2577-000	Logic Board
14-2578-000	Output Board
14-2574-000	Mother Board
14-2579-000	Interconnect Board
14-2580-000	Program Panel Display Board
14-2929-000	Wrapper Assembly (110V)
14-3325-000	Wrapper Assembly (220V)
14-2511-000	Expansion Slot Cover
14-0065-034	Fuses (5), 1.0 amp (110V & 220V)
14-3043-034	Fuses (5), 8.0 amp (rectifier) (110V)
14-3361-034	Fuses (5), 4.0 amp (rectifier) (220V)
14-0140-034	Fuses (5), 2.0 amp (110V & 220V)

## 6.5 Ordering Replacement Parts (cont.)

14-2432-000	Bracket, Transfer Line
14-2435-010	Cap Nut
14-2438-019	Heater Fan Blade
14-2436-000	Bracket, Sample Valve
14-0067-027	Allen Wrench
14-2987-000	Phillips Screwdriver
14-3046-035	Wago Tool for thermocouple connection
14-2428-000	Sample Shroud, Complete
14-2914-000	LSC 2000 User Manual (110V)
14-3345-000	LSC 2000 User Manual (220V)
14-3154-000	LSC 2000 Applications Manual

### INTERFACE CABLES

14-2976-000	HP 5710/30/90 GC w/5970 MSD w/Chemstation using Quicksilver
14-2990-000	HP 5880A/5840A
14-2991-000	HP 5890 GC/5890 w/5970 MSD or 5988 MS w/ Chemstation
14-3313-000	HP 5890 w/RTE and HP-1000 GC/MS Software w/ 5970 MSD or 5988 MS
14-3010-000	HP 5985/93/95 I/O Box GC/MS (requires HP's BATCH or AQUARIUS software & external events relay board to operate w/SIDS Data System)
14-2993-000	HP 5995/96/87/85 GC/MS with HP-1000/RTE GC/MS Software
14-2970-000	Perkin-Elmer Sigma Series
14-3233-000	Perkin-Elmer 8000 Series
14-2968-000	Varian 3400/3600 w/ Serial I/O
14-3433-000	Varian 3300/3400/3600 w/o Serial I/O
14-2969-000	Varian 3700
14-2966-000	Varian Vista (I/O Box & 2 Cables)
14-3430-000	Tracor 585
14-2972-000	Tracor 560, 565 and 570
14-2992-000	Tracor 540
14-2973-000	Schimadzu GC9A
14-3147-000	General Purpose
14-3318-000	HP 5995 GC/MS w/Chemstation and Quicksilver Software

*GENERAL MAINTENANCE*

**6.5  
Ordering  
Replacement  
Parts (cont.)**

**ACCESSORY CABLES**

14-3017-000	ALS to LSC 2000
14-3018-000	Model 1000 to LSC 2000
14-3372-000	DPU Printer to LSC 2000

**SECTION 7**  
**TROUBLESHOOTING**

---



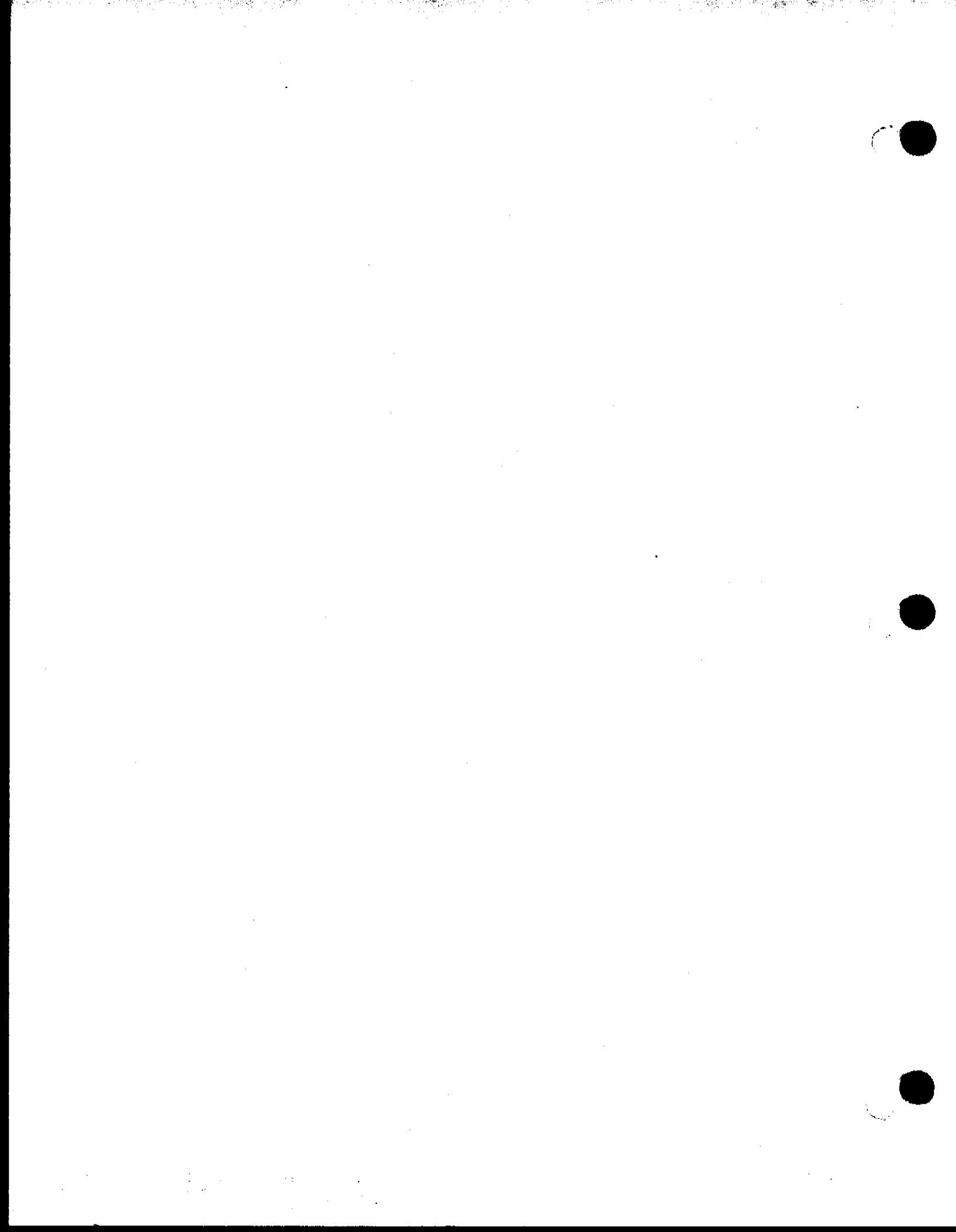

## 7.1 Electronic Problems

### #1 *No display or erratic display*

This section is intended as a guide to electronically troubleshooting your LSC 2000.

---

#### **CHECK**

#### **ACTION**

- |                                                                                        |                                                                            |
|----------------------------------------------------------------------------------------|----------------------------------------------------------------------------|
| A. Are fuses F1, F2, F3 still good?                                                    | A. YES: Proceed to B.<br>NO: Replace and try again.                        |
| B. With power on, press RESET (located next to the power switch). Does display appear? | B. YES: System is reset.<br>NO: Replace the CPU board or the power supply. |
- 

### #2 *Unsuccessful self tests*

- |                                                                                                                 |                                                                                            |
|-----------------------------------------------------------------------------------------------------------------|--------------------------------------------------------------------------------------------|
| A. Is fuse F2 good?                                                                                             | A. YES: Proceed to B.<br>NO: Replace fuse and retest. If failure still occurs, refer to C. |
| B. Does screen read FAILURE?                                                                                    | B. YES: Proceed to C.<br>NO: Replace the CPU board.                                        |
| C. Are resistance values for all heaters valid? Refer to Section 7.1.2 for resistance values.                   | C. YES: Proceed to D if fuses blow. If not, proceed to E.<br>NO: Replace heater.           |
| D. Remove oven fan and 6-port valve connectors on the inside of the front panel board. Are fuses still blowing? | D. YES: Call the Tekmar Service Dept.<br>NO: Replace oven fan or valve actuator.           |
| E. Did the displayed temperature appear to increase slightly?                                                   | E. YES: Replace the CPU board.<br>NO: Proceed to F.                                        |
| F. Does the thermocouple in question work properly?                                                             | F. YES: Proceed to G.<br>NO: Proceed to H.                                                 |

7.1  
Electronic  
Problems  
(cont.)

**#2**  
**Unsuccessful  
self tests  
(cont.)**

**#3**  
**System does  
not  
automatically  
step from  
Startup to  
Standby**

**CHECK**

G. Does the corresponding LED on the back panel come on?

H. Disconnect the thermocouple in question from the program panel board. Does the display read 410°C?

A. Is the front panel Hold LED on?

B. Is the front panel Auto LED on?

C. Are all temperatures at their set point?

D. Are all fuses good?

E. Are all resistance values for heaters valid? Refer to Section 7.1.2 for values.

F. Does corresponding light on back panel come on?

**ACTION**

G. YES: Replace the output board.  
NO: Replace the CPU or the logic board.

H. YES: Replace or repair the thermocouple.  
NO: Replace the logic board.

A. YES: Press AUTO.  
NO: Proceed to B.

B. YES: Proceed to C.  
NO: Proceed to D.

C. YES: Replace the CPU board.  
NO: Allow time to heat up then proceed to D.

D. YES: Proceed to E.  
NO: Replace and try again.

E. YES: Proceed to F.  
NO: Replace heater.

F. YES: Replace the output board.  
NO: Replace the logic board or the CPU.

**7.1  
Electronic  
Problems  
(cont.)**

#4

***System does  
not step from  
Standby to  
Purge Ready***

#5

***System does  
not step from  
Purge Ready  
to Purge.***

#6

***System does  
not step out of  
Purge.***

#7

***System does  
not step out of  
Dry Purge.***

#8

***System does  
not step out of  
Desorb Ready.***

**CHECK**

- A. Is trap temperature below the set point?
- B. Is the system in Auto?

**ACTION**

- A. YES: Proceed to B.  
NO: Wait for the trap to cool past the set point.
- B. YES: Replace the CPU.  
NO: Press AUTO.

- A. Does the system include an auto sampler?
- B. Does the Start LED on the I/O board come on?

- A. YES: Proceed to B.  
NO: Press START.
- B. YES: Replace the CPU or the I/O board.  
NO: Proceed to C.

- C. Are the DIP switches on the I/O board set correctly? Refer to Section 7.1.3.

- C. YES: Replace the CPU or the I/O board.  
NO: Set the switches correctly.

- A. Is system in Auto?
- B. Has the preset time elapsed?

- A. YES: Proceed to B.  
NO: Press AUTO.
- B. YES: Replace the CPU.  
NO: Wait for time to elapse.

- A. Refer to Problem #6.

- A. Is the system interfaced to a G.C.?
- B. Does the Continue LED on the I/O board come on when the G.C. is ready?

- A. YES: Proceed to B.  
NO: Press STEP.
- B. YES: Replace the CPU or the I/O board.  
NO: Proceed to C.

7.1  
Electronic  
Problems  
(cont.)

**#8**  
**System does  
not step out of  
Desorb Ready.**  
(cont.)

**#9**  
**System does  
not step out of  
Desorb  
Preheat.**

**#10**  
**System does  
not step out of  
Desorb.**

**#11**  
**System does  
not step out of  
Bake.**

**CHECK**

- C. Are the DIP switches on the I/O board set correctly? Refer to Section 7.1.3.  
D. Is the G.C. definitely providing a Ready signal to the 2000?

- A. Does the trap temp. equal or exceed the set temperature?  
B. Is the system in Auto?  
C. Is the trap heater temperature rising from ambient?  
D. Is the resistance value for the trap heater valid?  
E. Does the Trap Heater LED on the back panel come on?

A. Refer to Problem #6.

A. Refer to Problem #6.

**ACTION**

- C. YES: Proceed to D.  
NO: Set the switches correctly.  
D. YES: Replace the CPU or the I/O board.  
NO: Correct the G.C. problem.

- A. YES: Proceed to B.  
NO: Proceed to C.  
B. YES: Replace the CPU.  
NO: Proceed to C.  
C. YES: Allow time for it to rise to the set point.  
NO: Proceed to D.  
D. YES: Proceed to E.  
NO: Replace heater.  
E. YES: Replace the output board.  
NO: Replace the CPU or the logic board.

**SECTION 8**  
**LSC 2000 FIGURES**

---



*Tekmar*<sup>®</sup>

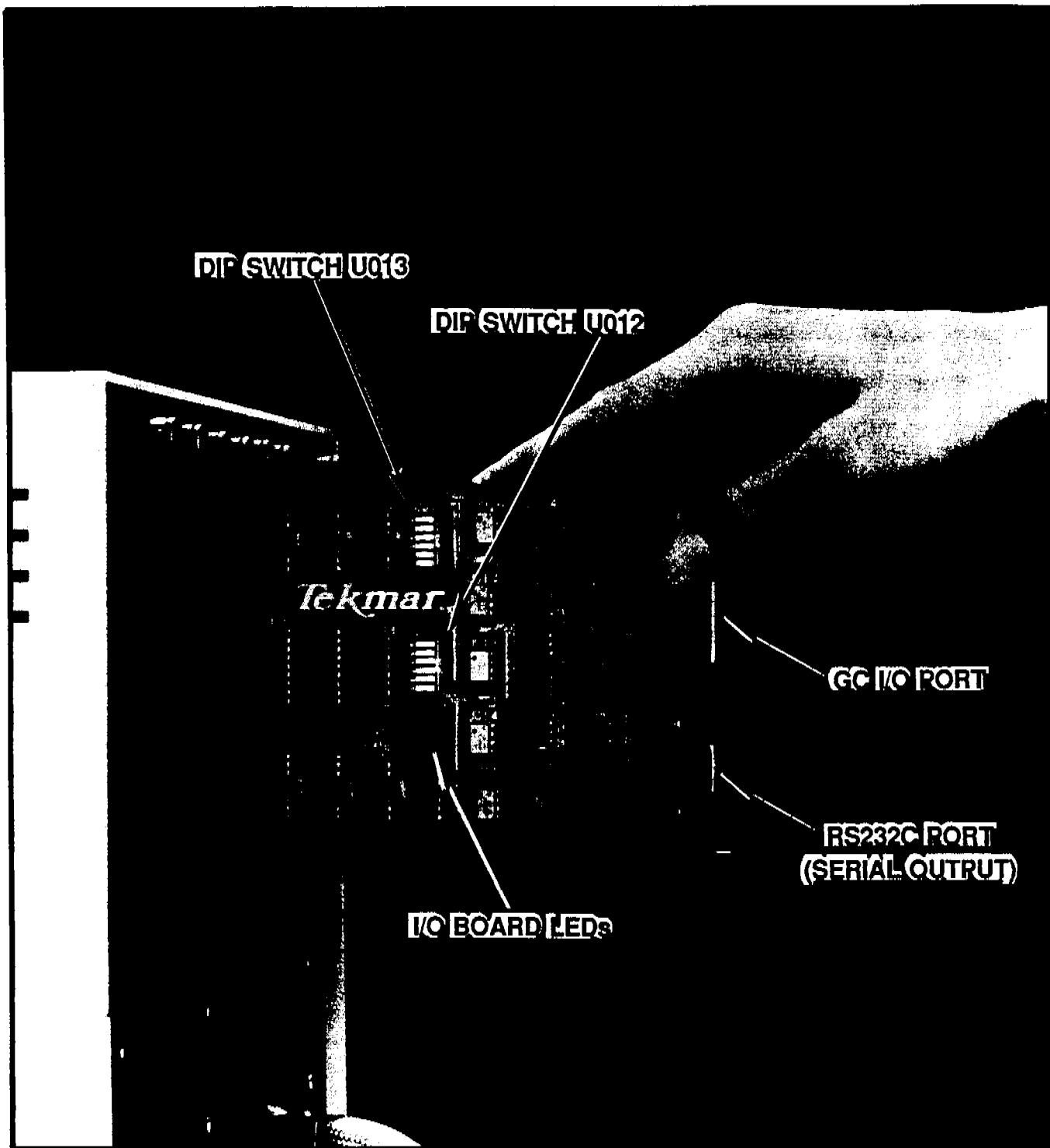

LSC 2000 I/O BOARD





**Tekmar®**

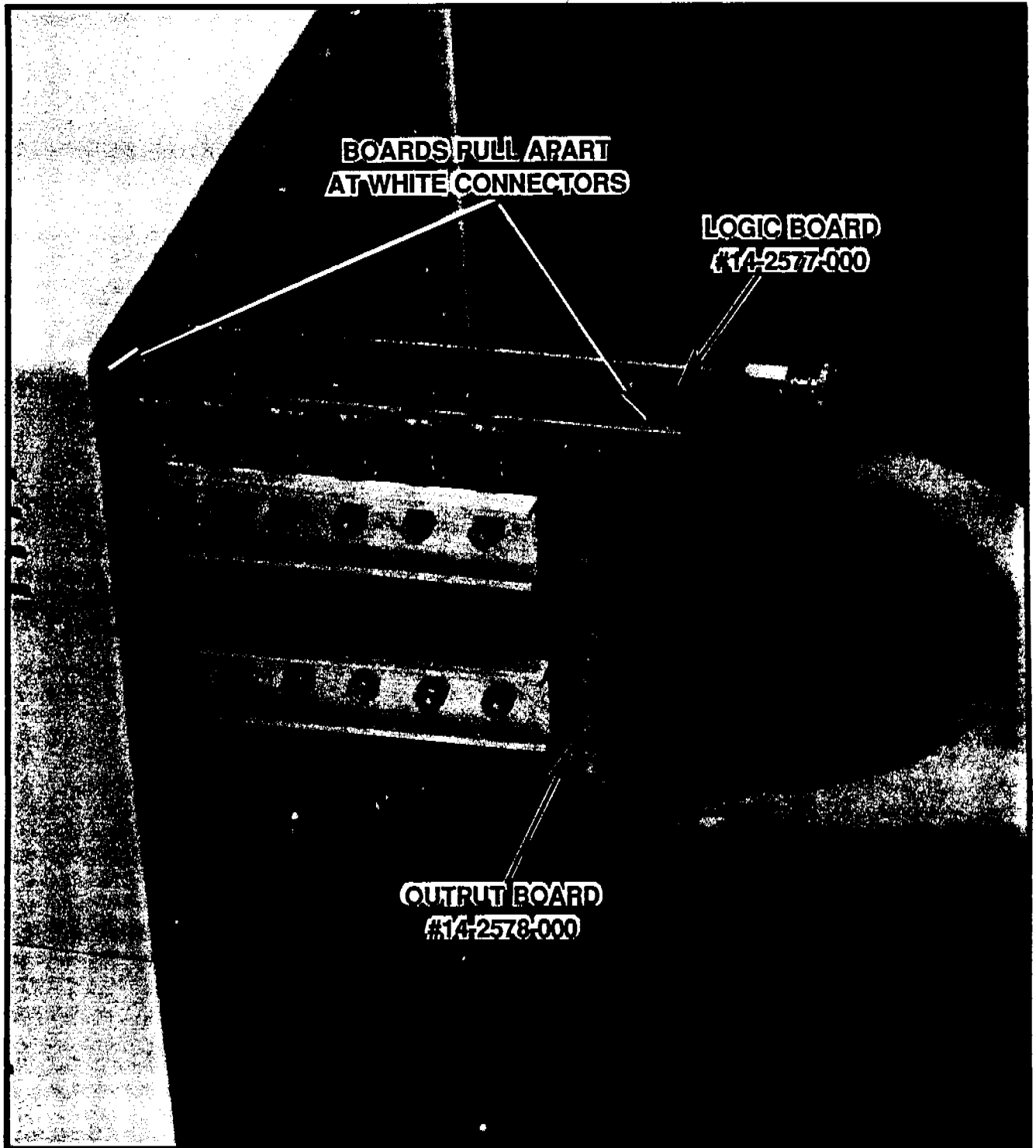

**LSC 2000 LOGIC & OUTPUT BOARDS**



**Tekmar®**

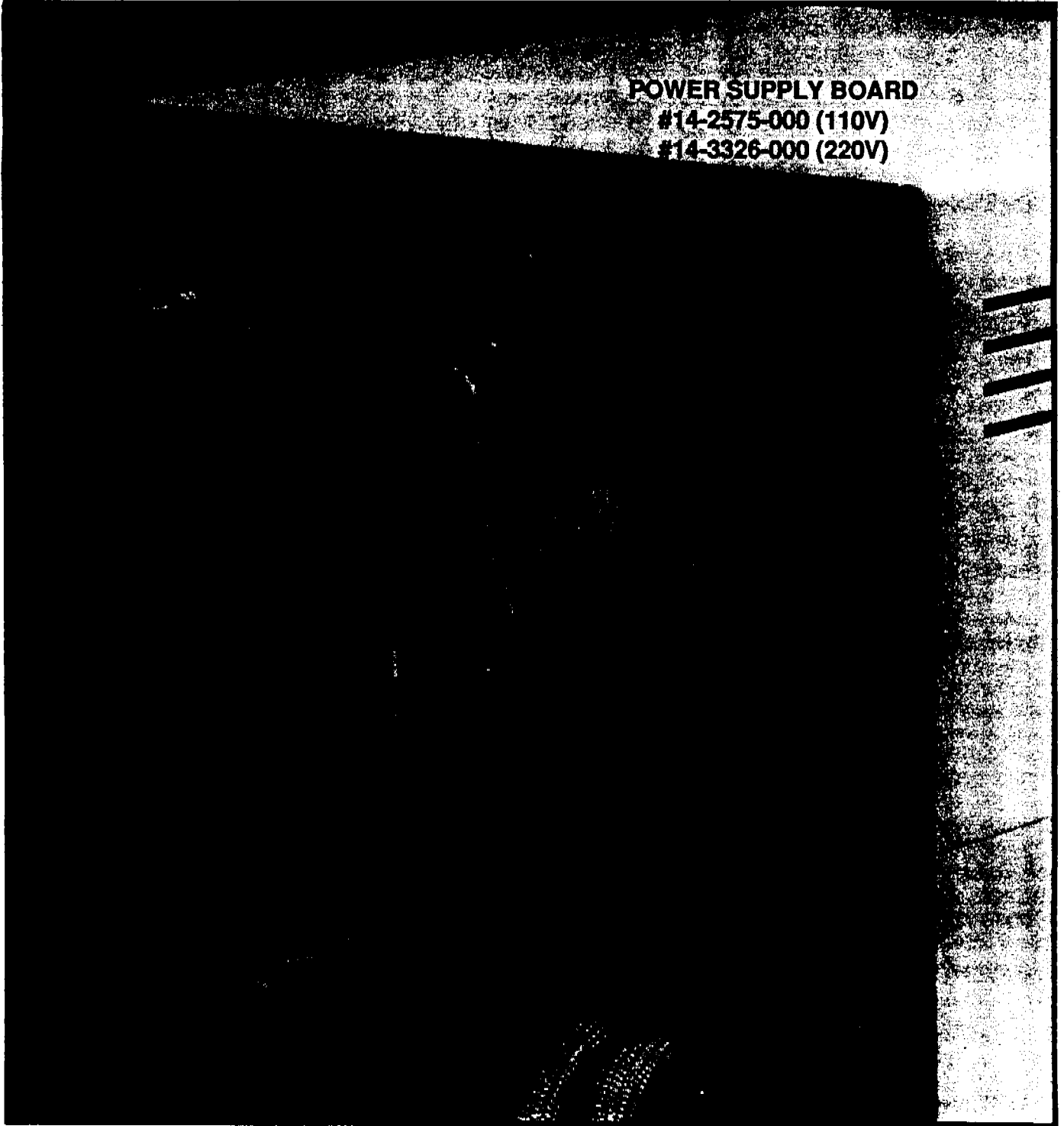

**POWER SUPPLY BOARD**

**#14-2575-000 (110V)**

**#14-3326-000 (220V)**

**LSC 2000 POWER SUPPLY BOARD**



**Tekmar®**

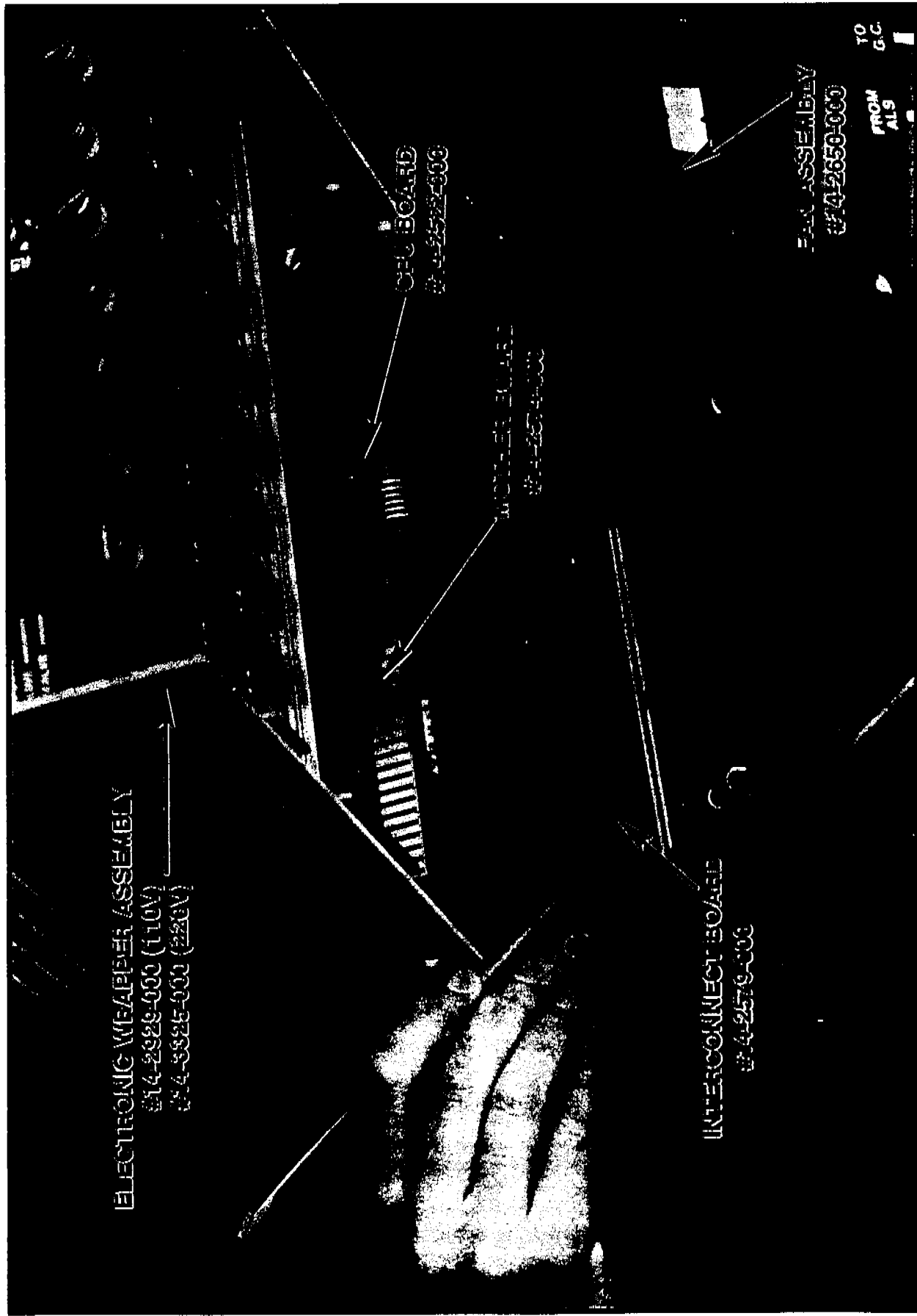

LSC 2000 ELECTRONICS MODULE CONNECTION



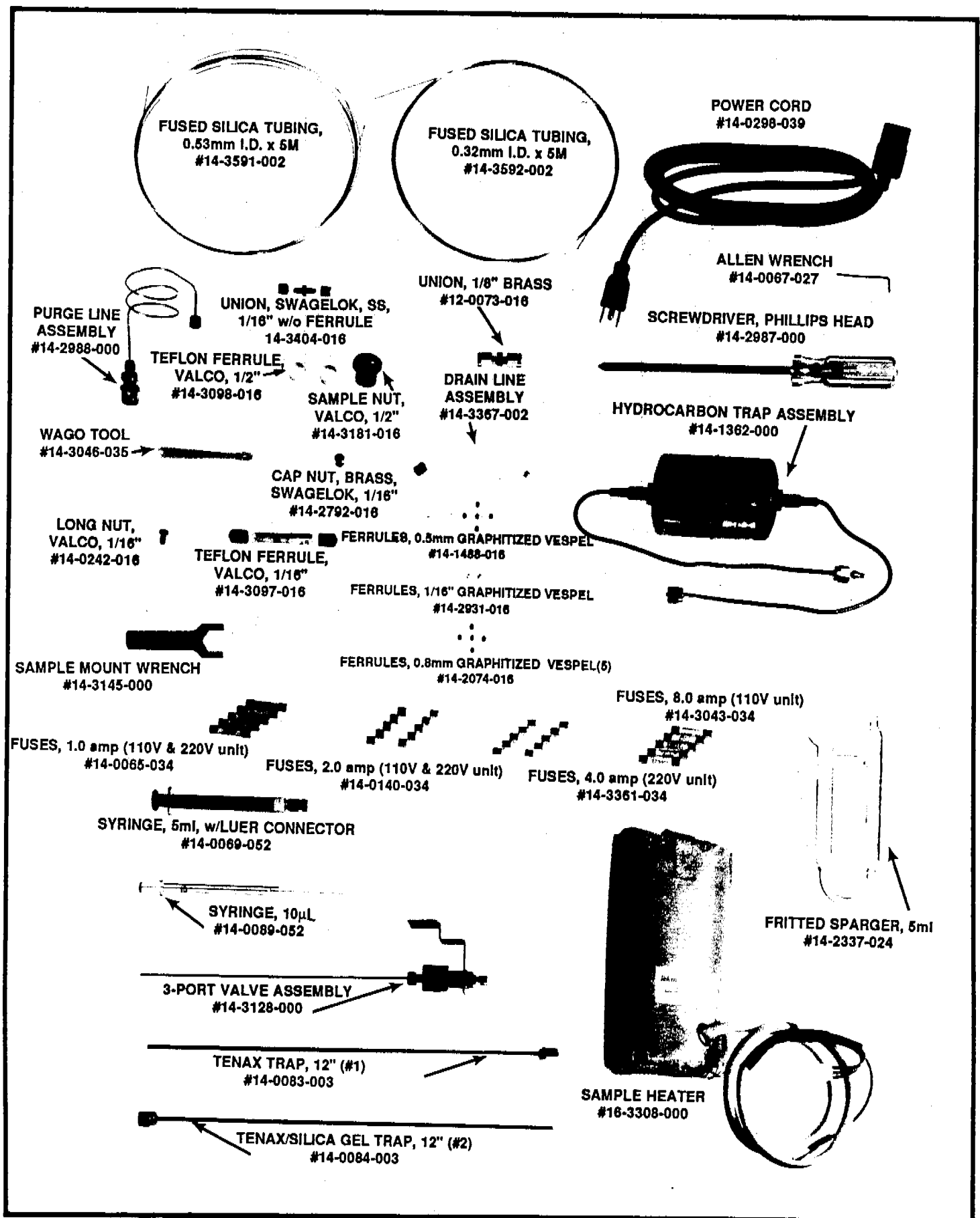

FUSED SILICA TUBING,  
0.53mm I.D. x 6M  
#14-3591-002

FUSED SILICA TUBING,  
0.32mm I.D. x 5M  
#14-3592-002

POWER CORD  
#14-0298-039

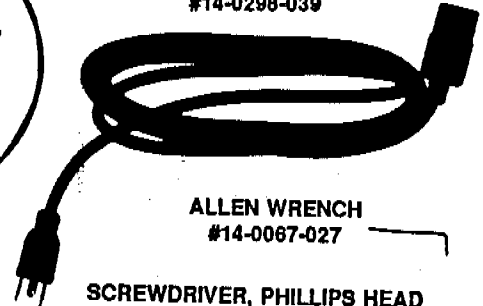

ALLEN WRENCH  
#14-0067-027

SCREWDRIVER, PHILLIPS HEAD  
#14-2987-000



HYDROCARBON TRAP ASSEMBLY  
#14-1362-000

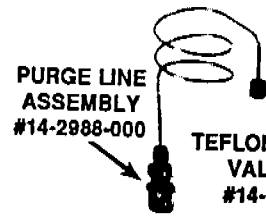
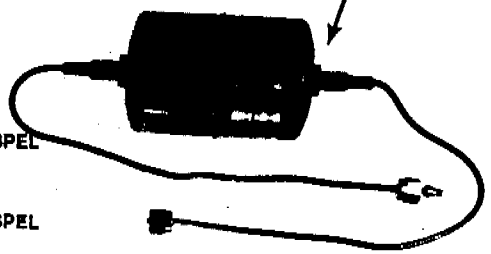

PURGE LINE ASSEMBLY  
#14-2988-000

UNION, SWAGELOK, SS,  
1/16" w/o FERRULE  
14-3404-016

UNION, 1/8" BRASS  
#12-0073-016

TEFLON FERRULE,  
VALCO, 1/2"  
#14-3098-016

SAMPLE NUT,  
VALCO, 1/2"  
#14-3181-016

DRAIN LINE ASSEMBLY  
#14-3367-002

WAGO TOOL  
#14-3046-035



CAP NUT, BRASS,  
SWAGELOK, 1/16"  
#14-2792-016

LONG NUT,  
VALCO, 1/16"  
#14-0242-016

TEFLON FERRULE,  
VALCO, 1/16"  
#14-3097-016

FERRULES, 0.5mm GRAPHITIZED VESPEL  
#14-1488-016

FERRULES, 1/16" GRAPHITIZED VESPEL  
#14-2931-016



SAMPLE MOUNT WRENCH  
#14-3145-000

FERRULES, 0.8mm GRAPHITIZED VESPEL(5)  
#14-2074-016

FUSES, 8.0 amp (110V unit)  
#14-3043-034

FUSES, 1.0 amp (110V & 220V unit)  
#14-0085-034

FUSES, 2.0 amp (110V & 220V unit)  
#14-0140-034

FUSES, 4.0 amp (220V unit)  
#14-3361-034

SYRINGE, 5ml, w/LUER CONNECTOR  
#14-0089-052



SYRINGE, 10µL  
#14-0089-052



3-PORT VALVE ASSEMBLY  
#14-3128-000

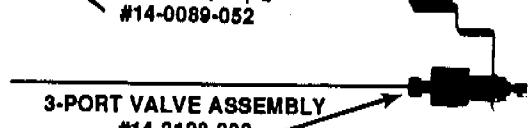

TENAX TRAP, 12" (#1)  
#14-0083-003

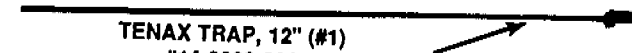

TENAX/SILICA GEL TRAP, 12" (#2)  
#14-0084-003



FRITTED SPARGER, 5ml  
#14-2337-024

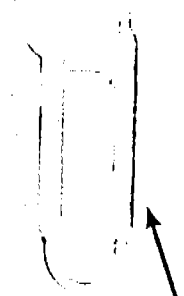

SAMPLE HEATER  
#16-3308-000

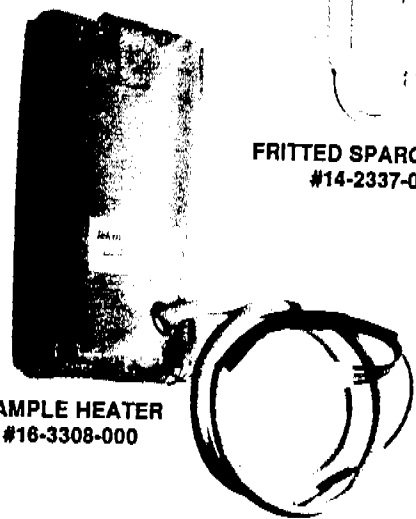





**Tekmar®**

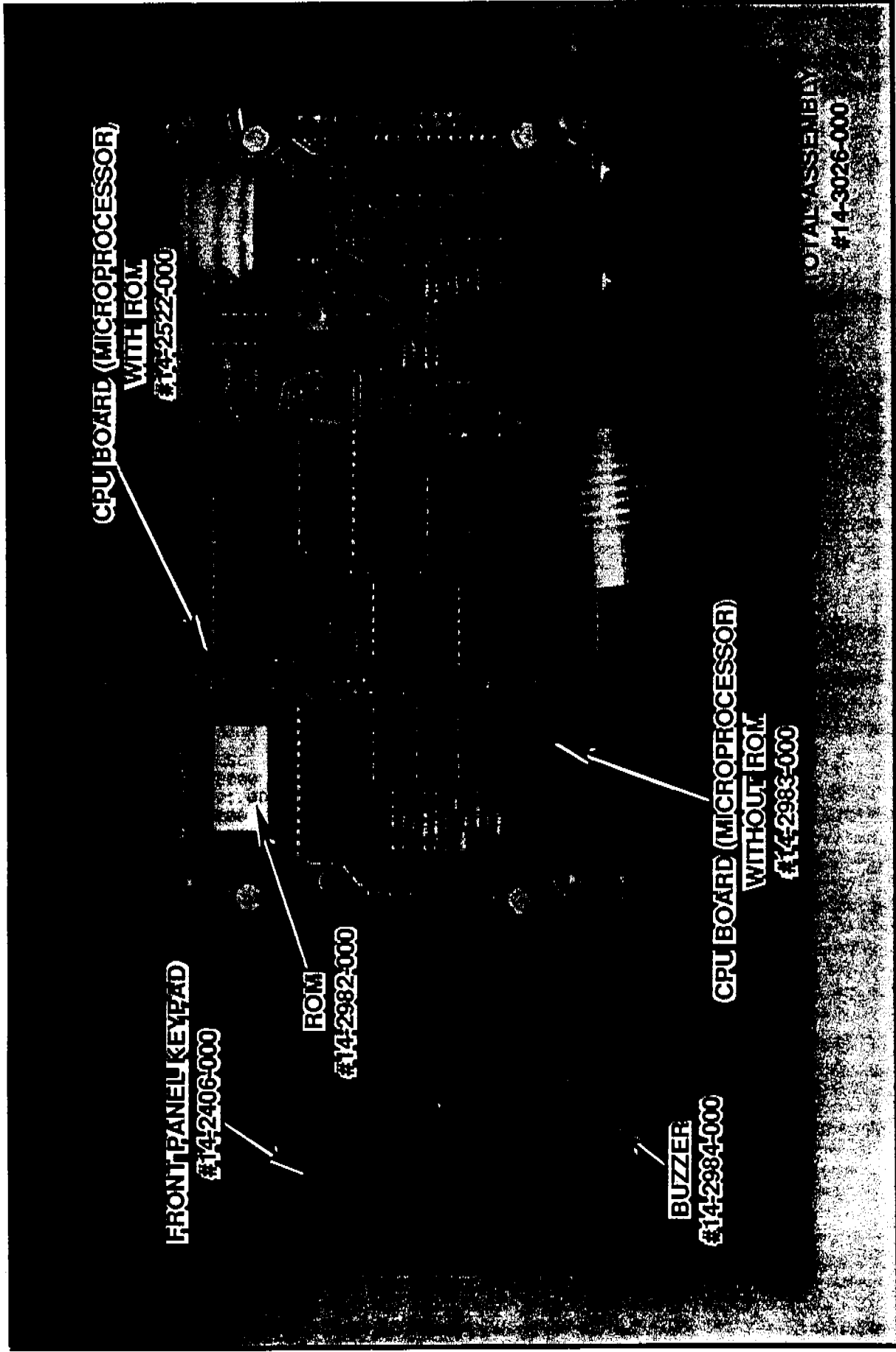

**CPU BOARD (MICROPROCESSOR)  
WITH ROM  
#14-2522-000**

**FRONT PANEL KEYPAD  
#14-2406-000**

**ROM  
#14-2982-000**

**BUZZER  
#14-2984-000**

**CPU BOARD (MICROPROCESSOR)  
WITHOUT ROM  
#14-2983-000**

**TOTAL ASSEMBLY  
#14-3026-000**

**LSC 2000 CPU BOARD & KEYPAD**



OUTPUTS							
MODES	PURGE VALVE	VENT VALVE	HRP VALVE	DRAIN VALVE	BYPASS VALVE	SIX PORT VALVE	TRAP FAN
START-UP						P	☼
STANDBY						P	☼
PURGE READY						P	☼
PURGE	☼	☼				P	☼
DRY PURGE	☼	☼			☼	P	☼
DESORB READY						P	☼
DESORB PREHEAT						P	
DESORB						D	
DESORB W/DRAIN	☼		☼	☼		D	
BAKE	☼	☼				P	
BAKE W/BGB	☼	☼			☼	P	

☼ INDICATES OUTPUT IS ON

P ■ SIX PORT (MULTI-PORT) VALVE IS IN THE PURGE MODE CONFIGURATION. (REFER TO FLOW DIAGRAM)

D ■ SIX PORT (MULTI-PORT) VALVE IS IN THE DESORB MODE CONFIGURATION. (REFER TO FLOW DIAGRAM)



# Tekmar®

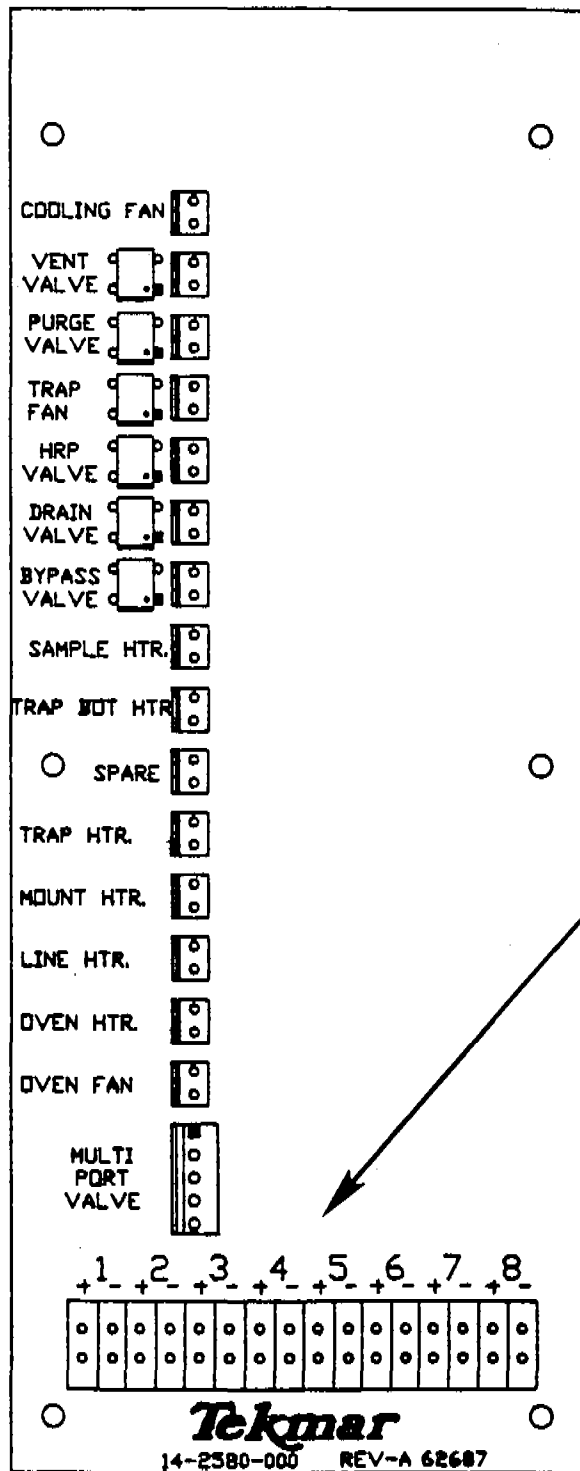

## THERMOCOUPLE POSITIONS

1. Line Heater
2. Spare
3. Sample Heater
4. Trap Heater
5. Oven Heater
6. Mount Heater
7. Spare
8. B.O.T. Heater

INTERIOR VIEW OF THE PROGRAM PANEL

LSC 2000 THERMOCOUPLE POSITIONS



# Tekmar®

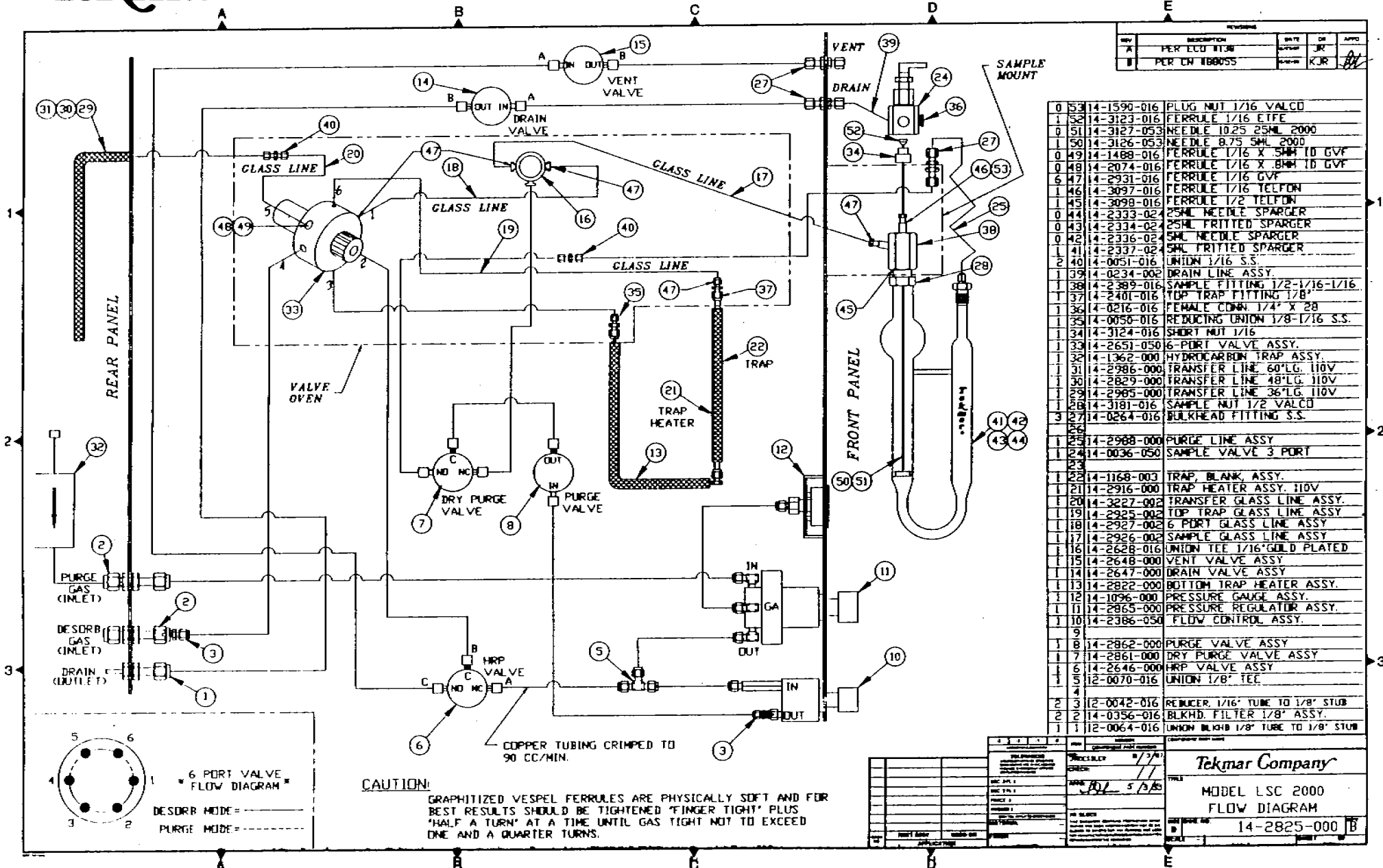

LSC 2000 FLOW DIAGRAM (110V)









# Tekmar®

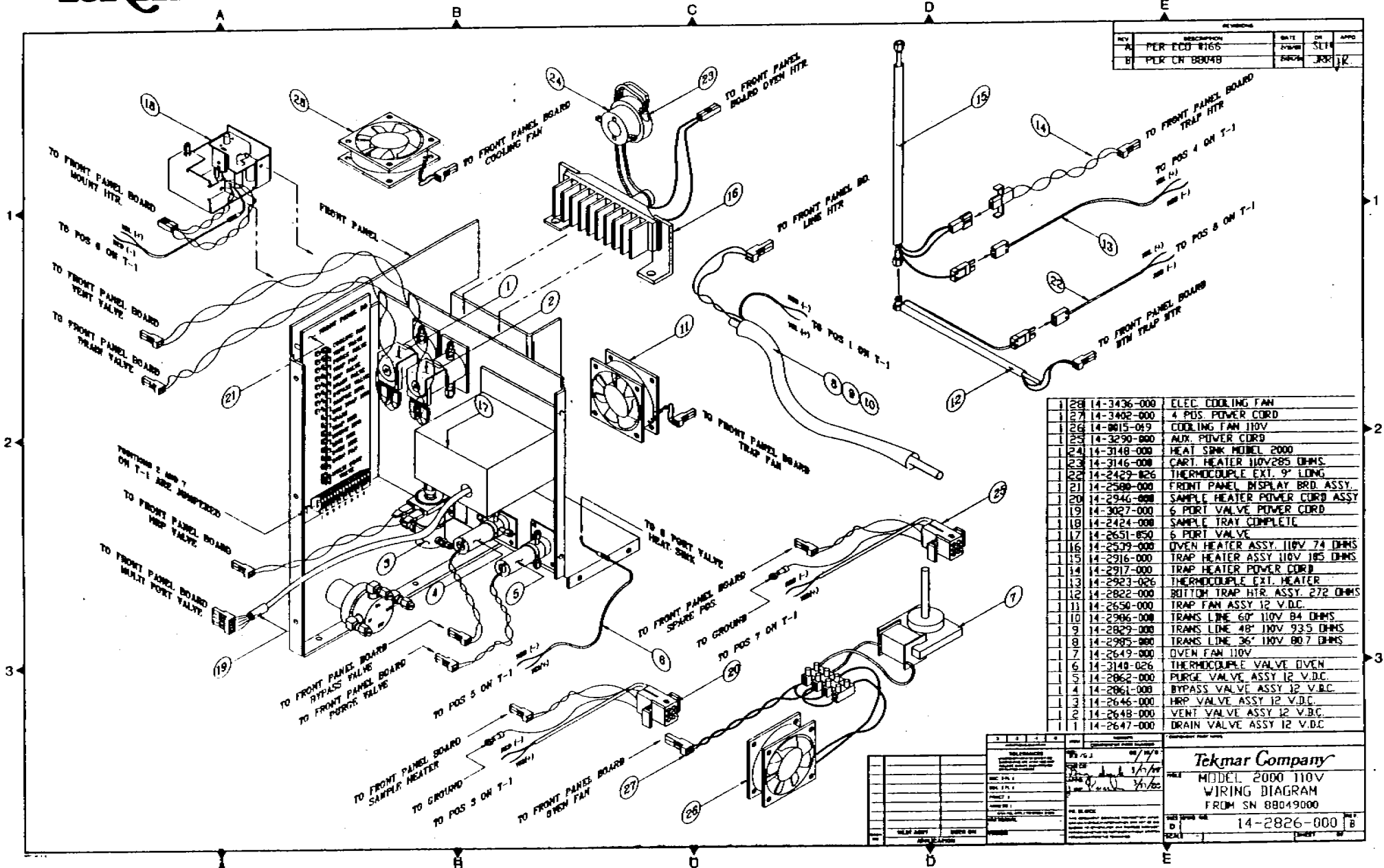

REV	DESCRIPTION	DATE	BY	APPD
A	PER ECO #166			
B	PLR CH 88048		JRK	JR

1	28	14-3436-000	ELEC. COOLING FAN
1	27	14-3402-000	4 POS. POWER CORD
1	26	14-0615-019	COOLING FAN 110V
1	25	14-3290-000	AUX. POWER CORD
1	24	14-3148-000	HEAT SINK MODEL 2000
1	23	14-3146-000	CART. HEATER 110V/285 OHMS
1	22	14-2422-026	THERMOCOUPLE EXT. 9" LONG
1	21	14-2500-000	FRONT PANEL DISPLAY BRD. ASSY.
1	20	14-2946-000	SAMPLE HEATER POWER CORD ASSY
1	19	14-3027-000	6 PORT VALVE POWER CORD
1	18	14-2424-000	SAMPLE TRAY COMPLETE
1	17	14-2651-050	6 PORT VALVE
1	16	14-2539-000	OVEN HEATER ASSY. 110V 74 OHMS
1	15	14-2916-000	TRAP HEATER ASSY 110V 105 OHMS
1	14	14-2917-000	TRAP HEATER POWER CORD
1	13	14-2923-026	THERMOCOUPLE EXT. HEATER
1	12	14-2822-000	BTM TRAP HTR. ASSY. 272 OHMS
1	11	14-2650-000	TRAP FAN ASSY 12 V.D.C.
1	10	14-2906-000	TRANS LINE 60" 110V 84 OHMS
1	9	14-2829-000	TRANS LINE 48" 110V 93.5 OHMS
1	8	14-2985-000	TRANS LINE 36" 110V 80.7 OHMS
1	7	14-2649-000	OVEN FAN 110V
1	6	14-3148-026	THERMOCOUPLE VALVE OVEN
1	5	14-2062-000	PURGE VALVE ASSY 12 V.D.C.
1	4	14-2061-000	BYPASS VALVE ASSY 12 V.B.C.
1	3	14-2646-000	HRP VALVE ASSY 12 V.D.C.
1	2	14-2648-000	VENT VALVE ASSY 12 V.B.C.
1	1	14-2647-000	DRAIN VALVE ASSY 12 V.D.C.

DATE: 11/7/88 BY: [Signature] CHECKED: [Signature]		<b>Tekmar Company</b> MODEL 2000 110V WIRING DIAGRAM FROM SN 88049000	
PART NO. 14-2826-000 QTY 1		14-2826-000 B	

LSC 2000 WIRING DIAGRAM (110V)



# Tekmar®

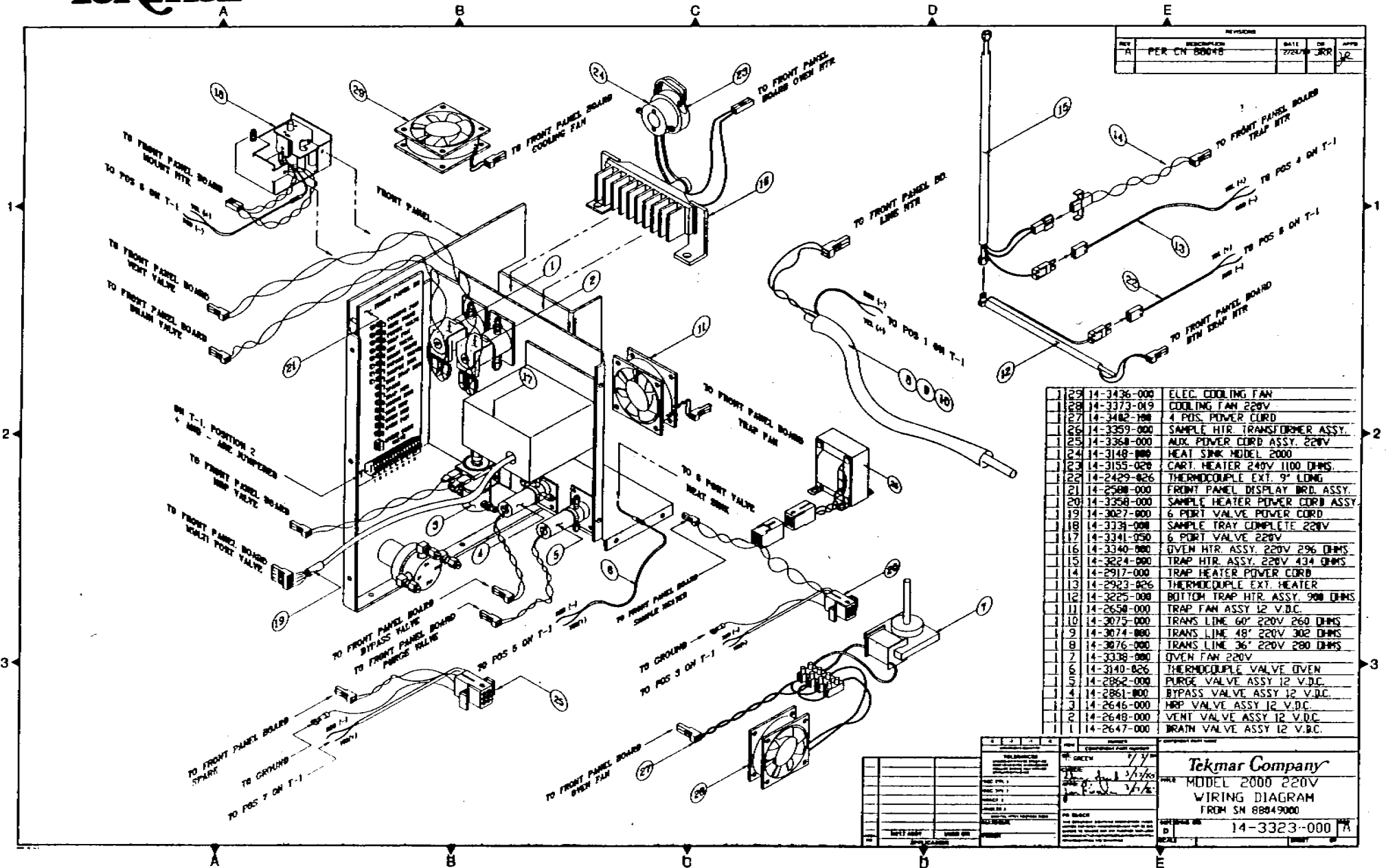

LSC 2000 WIRING DIAGRAM (220V)









# Tekmar®

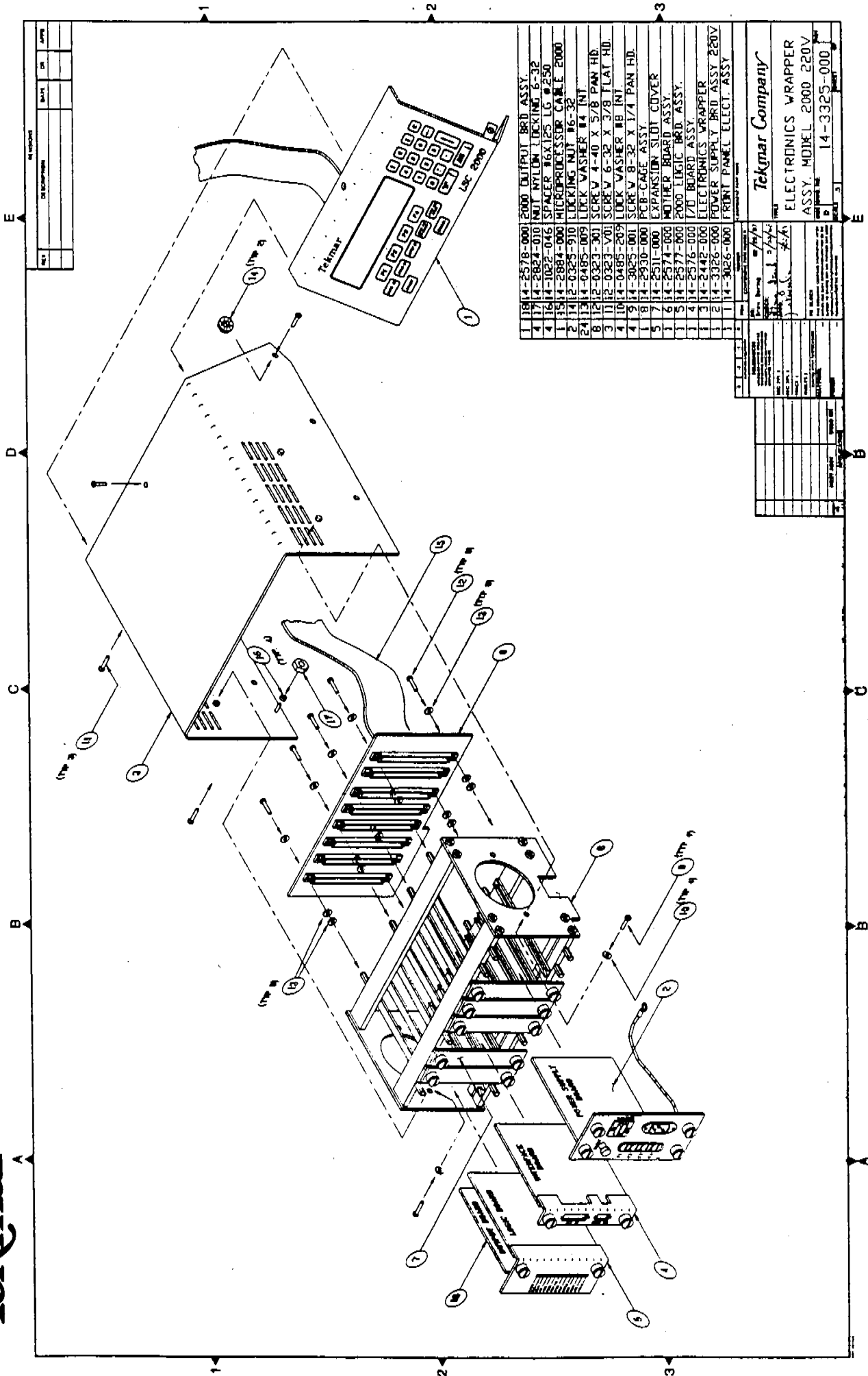

## LSC 2000 ELECTRONICS WRAPPER ASSEMBLY (220V)

**Tekmar Company**  
 ELECTRONICS WRAPPER  
 ASSY. MODEL 2000 220V  
 P. No. 14-3325-000



# Tekmar

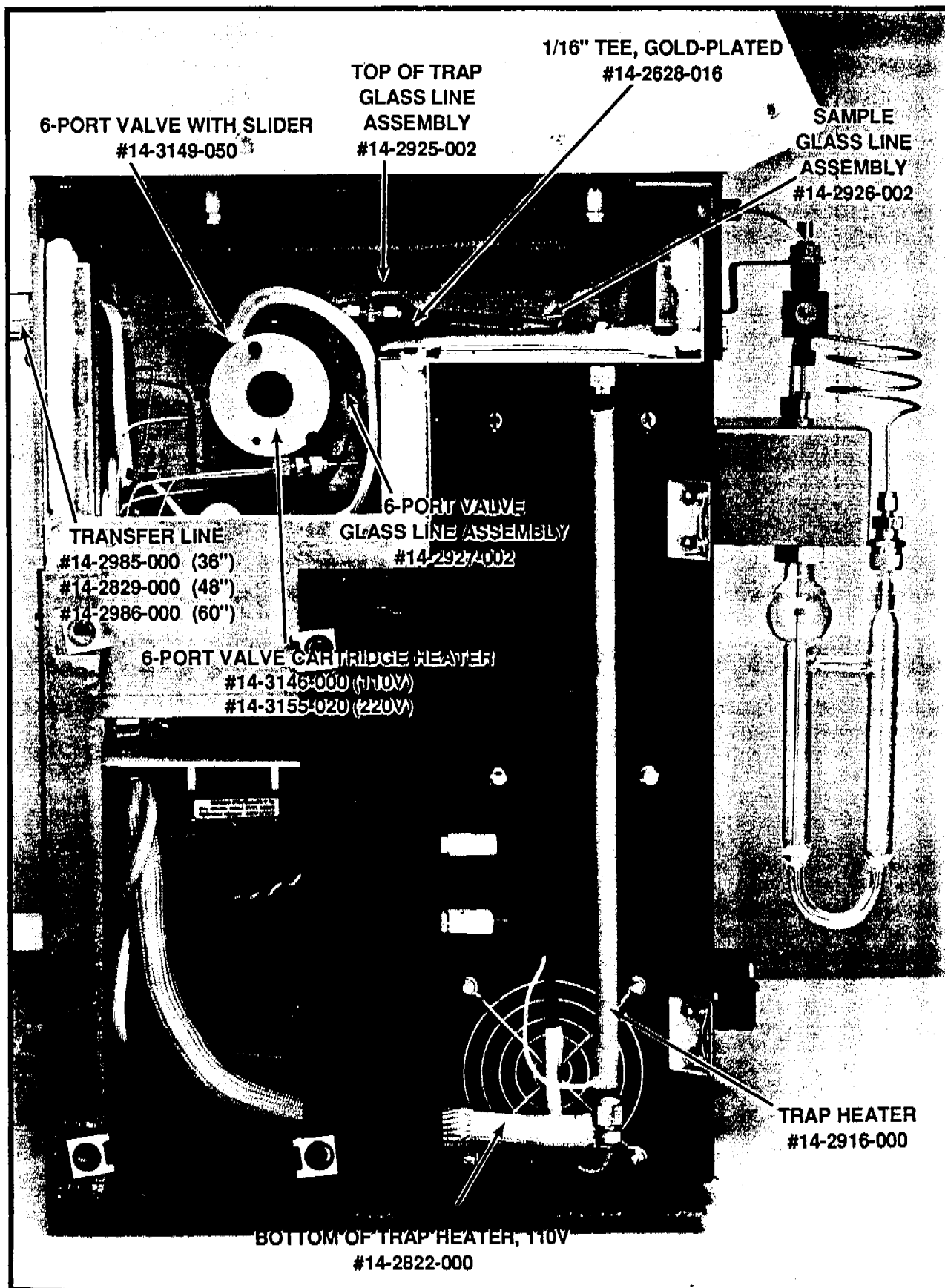

LSC 2000 VALVE OVEN & TRAP AREA



**Tekmar**<sup>®</sup>

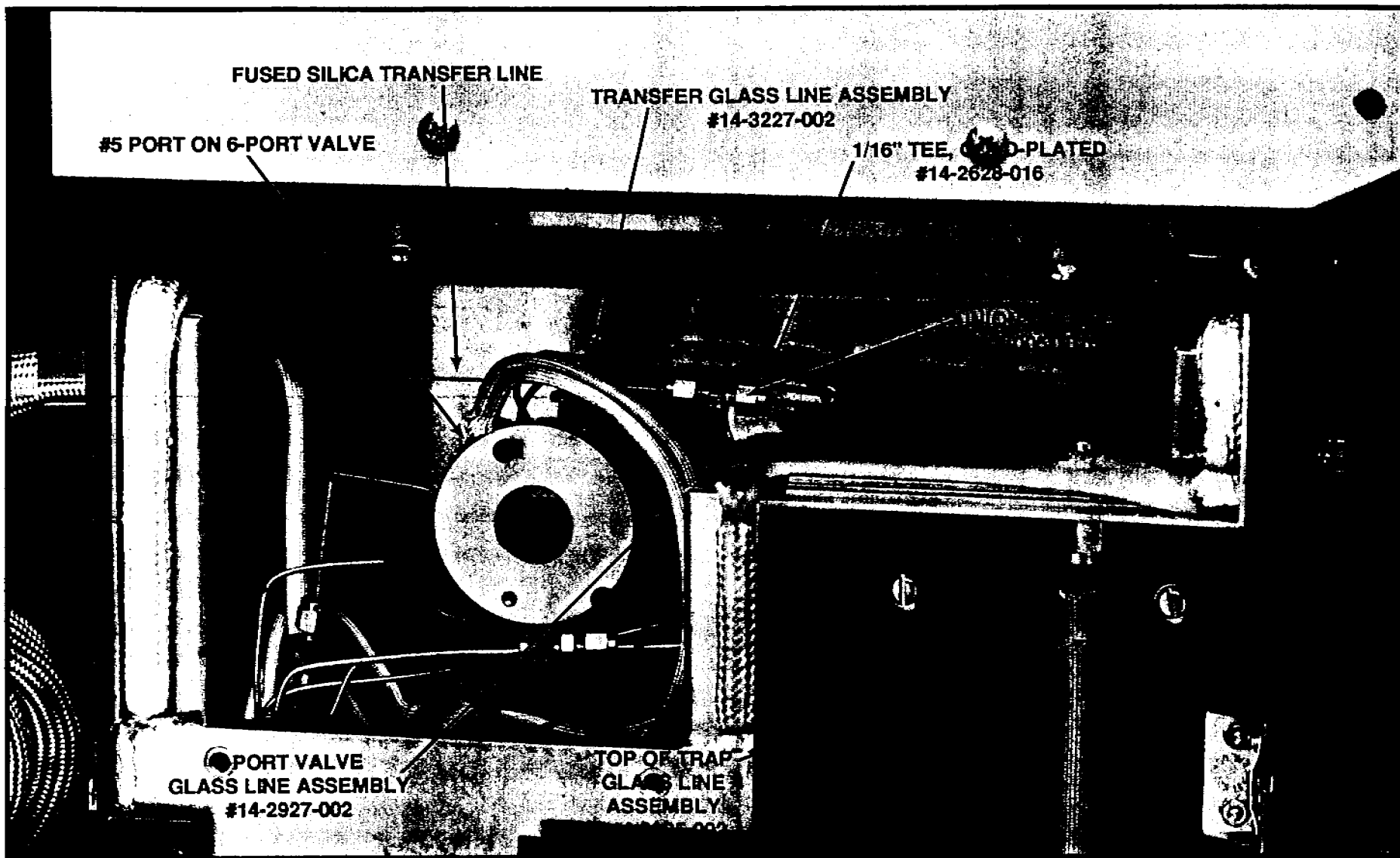

LSC 2000 VALVE OVEN

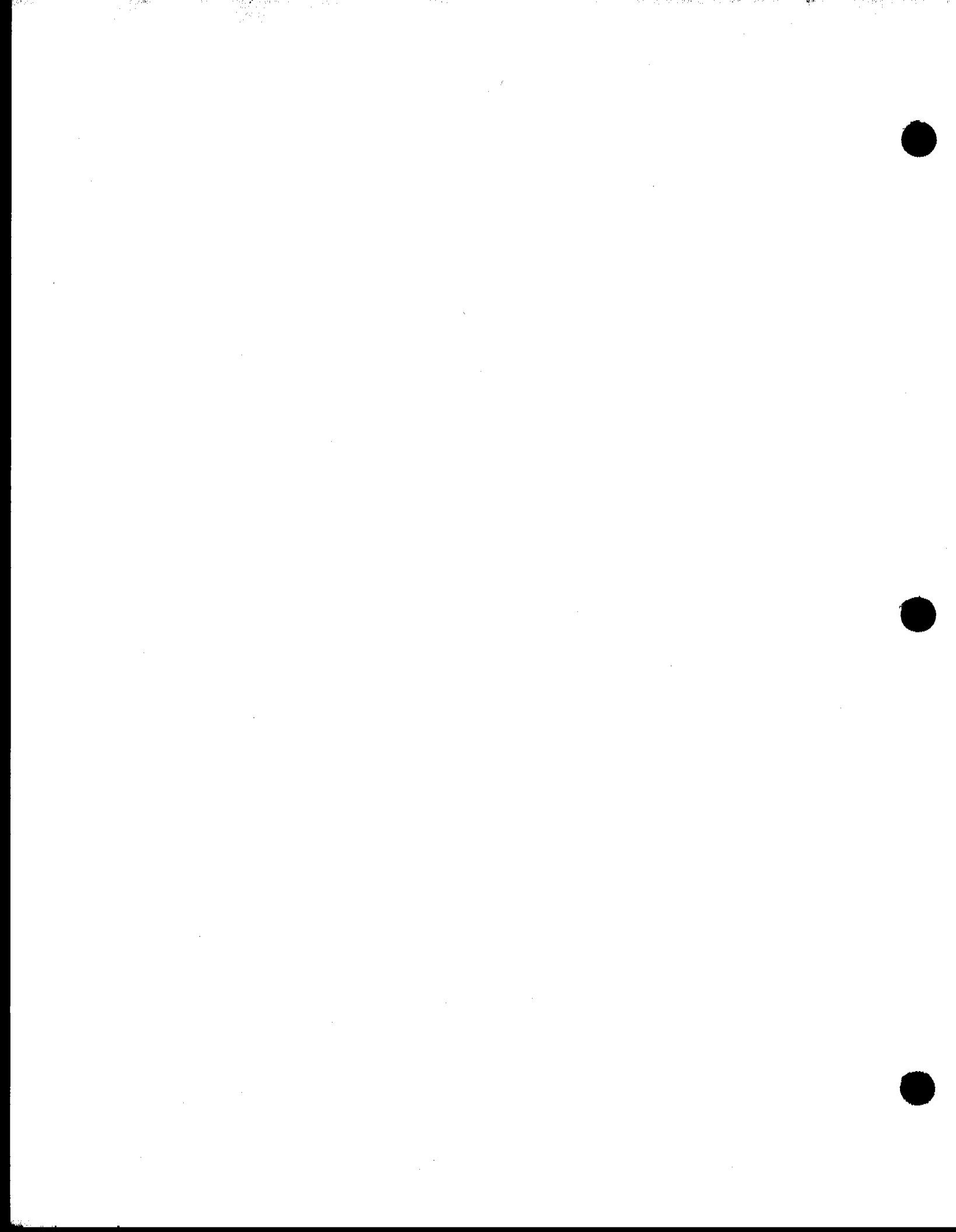

*Tekmar*<sup>®</sup>

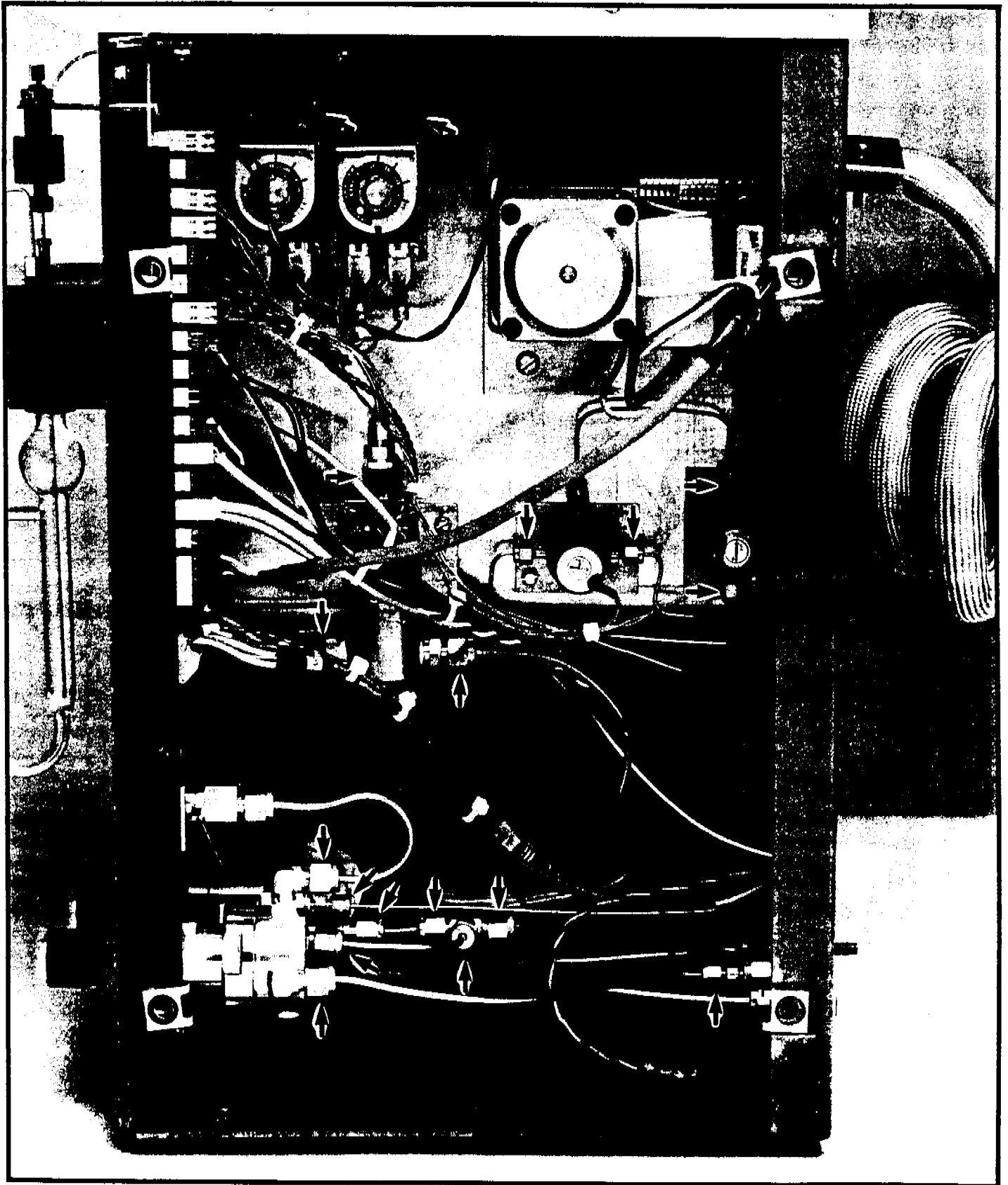

LSC 2000 LEAK CHECK DIAGRAM





# STANDBY MODE

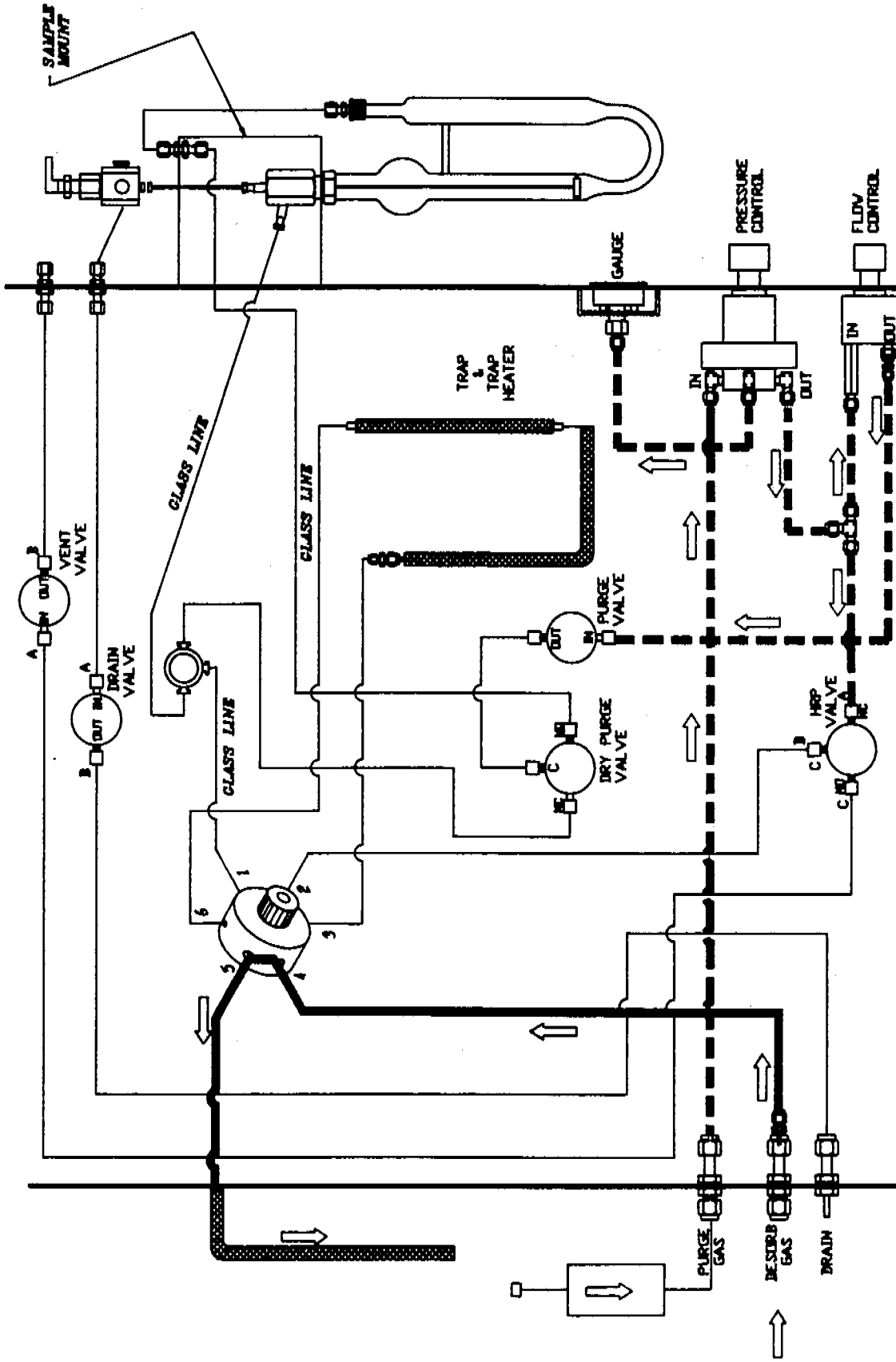

--- DENOTES PRESSURE ONLY



# PURGE/BAKE MODE (BGB OFF)

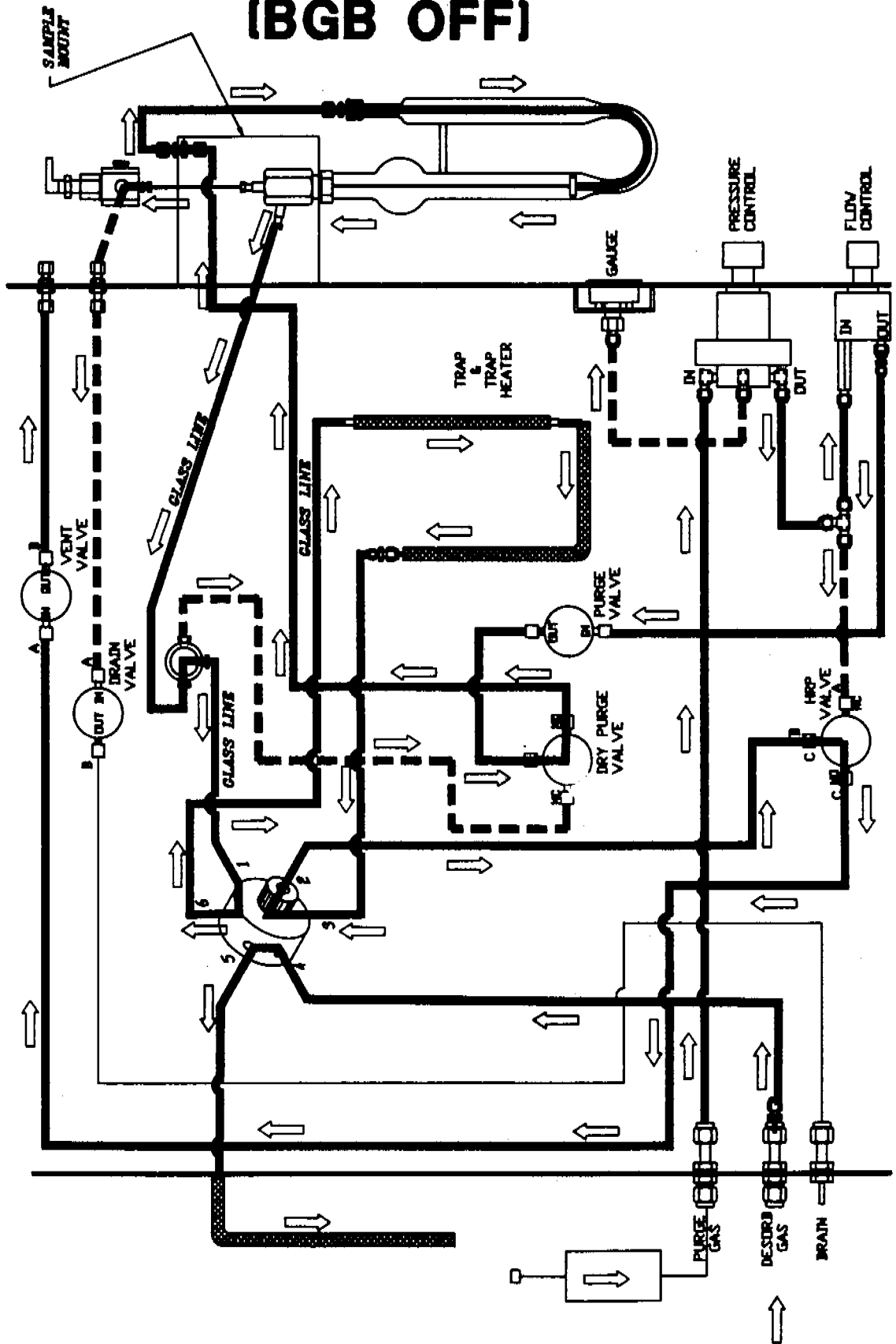

----- DENOTES PRESSURE ONLY



# DRY PURGE/BAKE MODE (BGB ON)

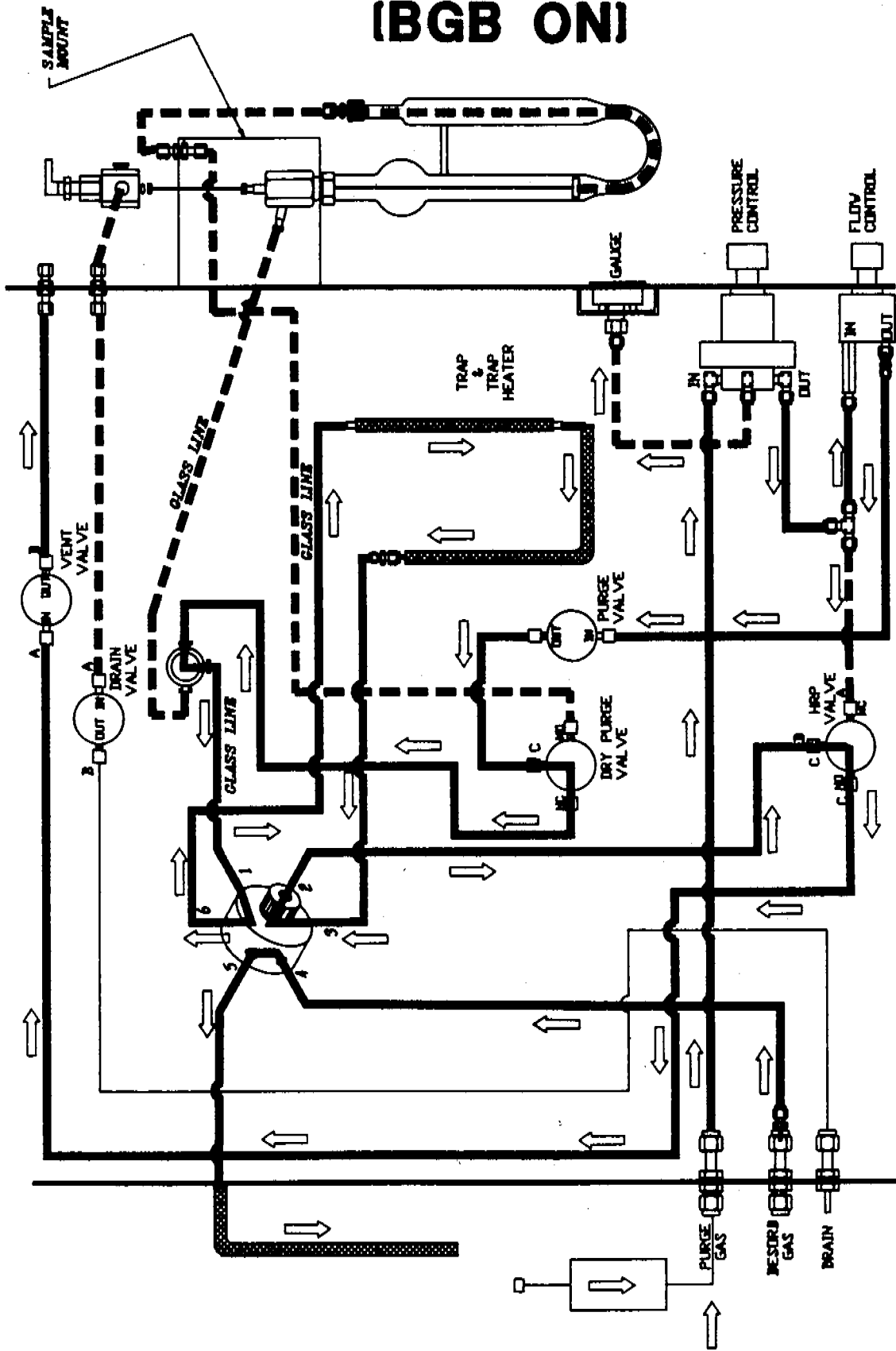

----- DENOTES PRESSURE ONLY



# DESORB MODE

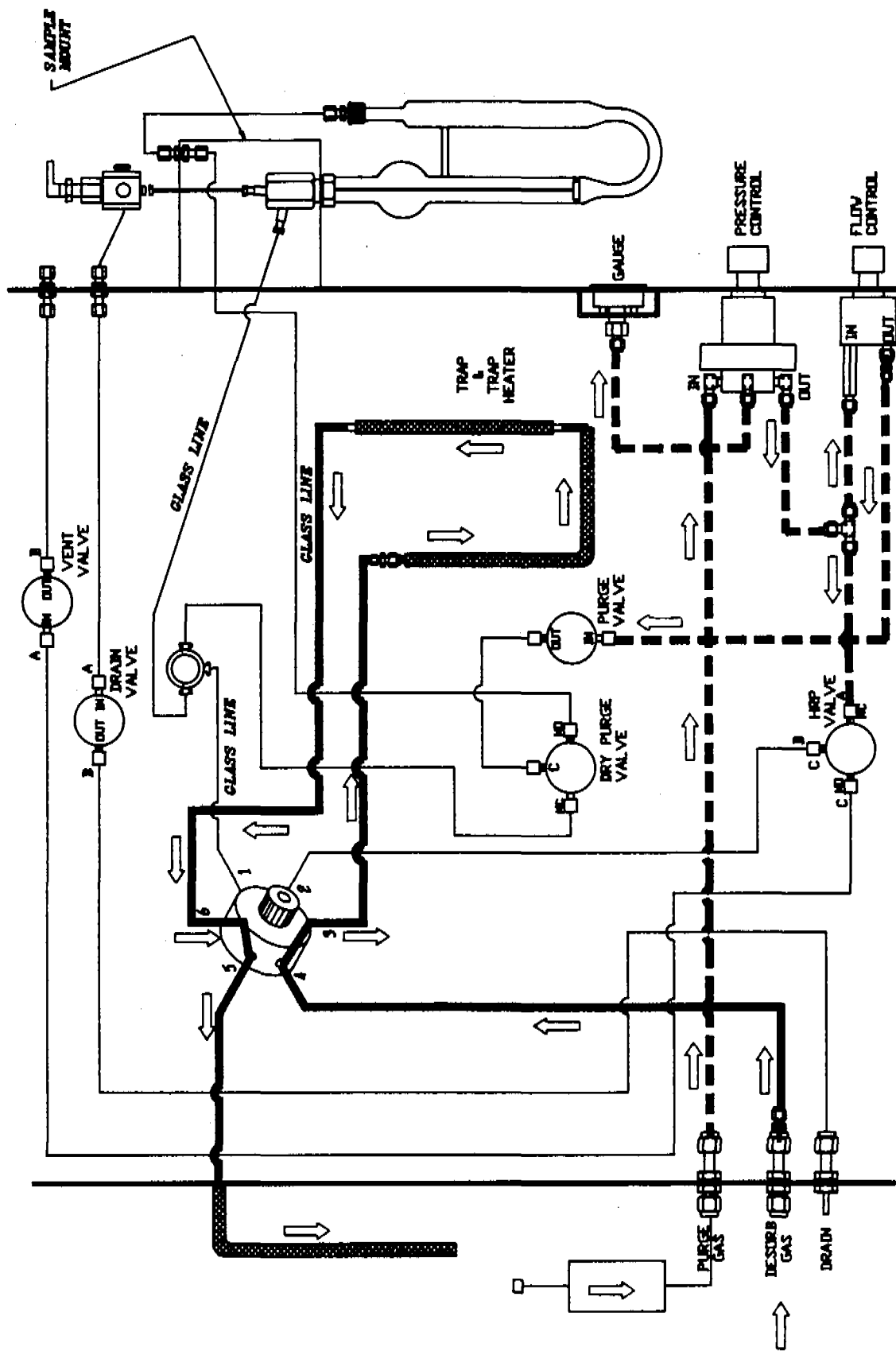

----- DENOTES PRESSURE ONLY





# DESORB & DRAIN MODE

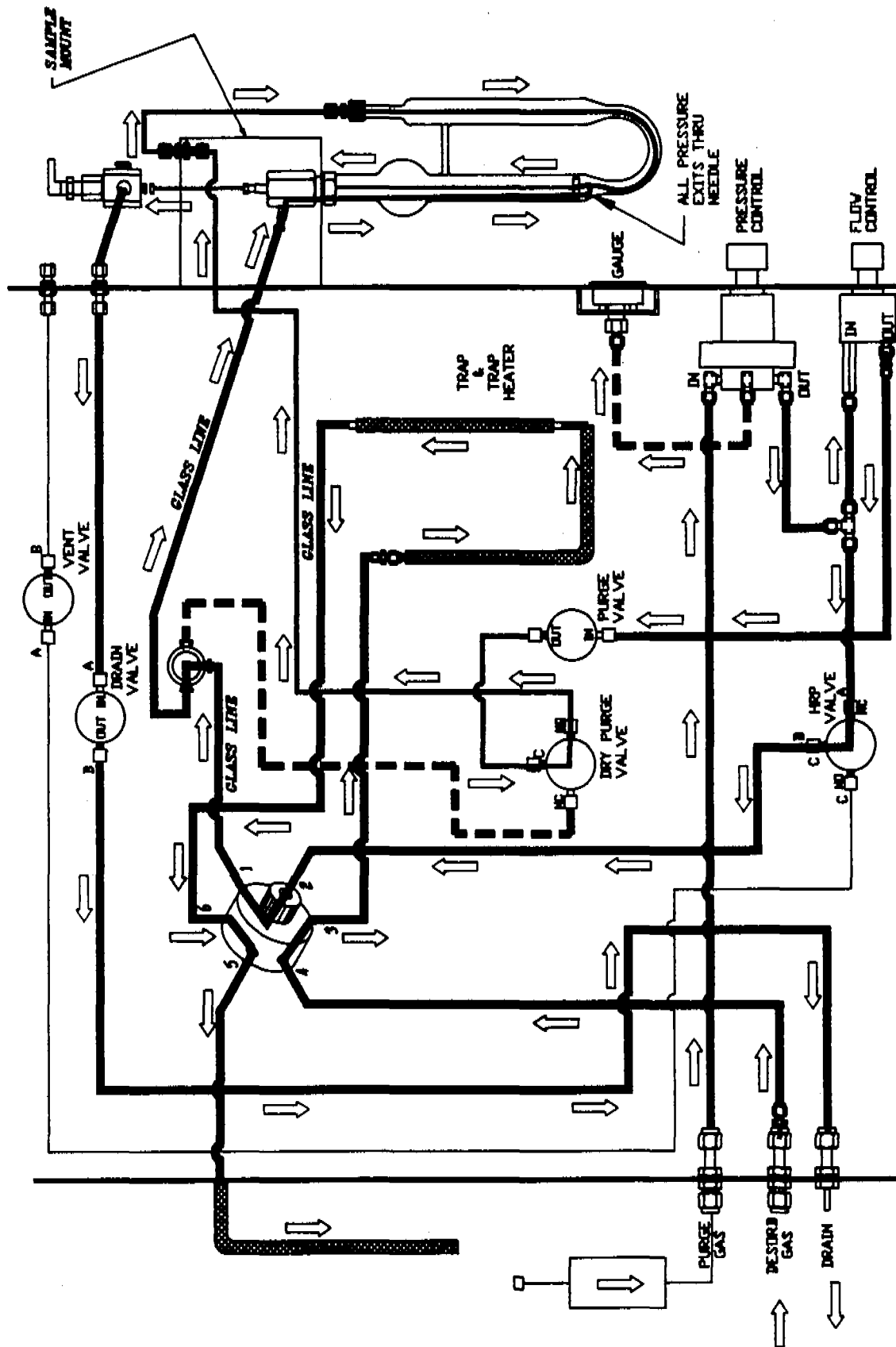

----- DENOTES PRESSURE ONLY



- A** | Auto Drain, 50  
ALS 2016, Accessories section  
ALS 2032, Accessories section
- B** | Bake mode, 31  
Bake Gas Bypass, 51  
Baud rate, 23  
Blank trap, 4, 17
- C** | Capillary columns, connection to, 13  
Capillary Interface, Accessories section  
Carrier gas connection, 12  
    Diagram of, 9  
Clock, 42  
Cooldown mode, 30  
CPU (Microprocessor) board, Section 8
- D** | Desorb mode, 31  
Desorb preheat mode, 31  
Desorb ready mode, 30  
DIP switches, 73  
Drain tubing (on rear panel), 20  
Drain line (on sample valve), 7  
Dry purge mode, 30
- E** | Electronics module connection, Section 8  
Electronic troubleshooting, 69  
EPA procedures, 64
- F** | Fritted disc sparger, 7  
Fused silica tubing  
    Installation of, 11  
    Handling of, 19  
Fuses  
    Location of, 20  
    Fuse ratings, 73
- G** | G.C. (Gas Chromatograph)  
    Electronic connection to the LSC 2000, 20  
    Pneumatic connection to the LSC 2000, 9  
Glassware  
    Sizes available, 2  
    Installation of, 7  
    Cleaning of, 67

## INDEX

- H** Hydrocarbon trap  
Installation, 9  
Photograph of, Section 8
- I** Inject mode, 31  
Instrument configuration (for accessories), 43  
Interface cables, 73  
Introductory screen, 21  
I/O board  
Location of, 20  
Photograph of, Section 8
- K** Kit Box Assembly  
Contents of, 6  
Photograph of, Section 8
- L** LCD (Liquid Crystal Display)  
Specifications, 2  
Interior photograph of, Section 8  
Viewing angle adjustment of, 33  
Leak checking, 16  
Logic board  
Location of, 20
- M** Method parameter values, 46  
Motherboard, Section 8
- N** Needle sparger, 8  
Needle bushing  
Location of, 7
- O** Operating temperature requirements, 3  
Output board,  
Location of, 20  
Photograph of, Section 8  
Output operational summary, Section 8

- P**
- Packed column injection ports, 12
  - Plug septa
    - Location of, 7
  - Power supply board
    - Location of, 20
    - Photograph of, Section 8
  - Preheat mode, 29
  - Prepurge mode, 29
  - Program panel, 27
    - Interior view of, Section 8
  - Purge bulkhead
    - Location of, 7
  - Purge gas requirements, 3
  - Purge line
    - Location of, 7
  - Purge mode, 29
  - Purge ready mode, 28
- Q**
- Quantitating a run, 59
- R**
- RAM (Random Access Memory), 34
  - Relative humidity requirements, 3
  - Reset switch,
    - Location of, 20
- S**
- Sampler mount
    - Location of, 7
  - Sample valve
    - Location of, 7
  - Self tests, 32
  - Serial port (RS232C)
    - Location of, 20
    - Description of, 22
    - Specifications, 3
  - Six-port valve
    - Location of, 11, Section 8
  - Specifications, 2
  - Standby mode, 27
  - STEP TO BAKE, 50
  - STEP TO STANDBY, 49
  - Storage temperature requirements, 3

- T
  - Thermocouple positions, Section 8
  - Transfer line, heated, 11
  - Traps
    - Blank traps, 4, 17
    - Changing a trap, 17
    - Identifying a trap (trap numbers), 18
    - Conditioning a new trap, 66
    - Optional traps, 2
  - Tubing
    - Specifications, 2
    - Drain tubing connection, 20
- U
  - Unpacking the unit, 4
  - Utilities, 3
- V
  - Valving, 2
  - Voltage specifications, 3
- W
  - Warnings, 1
  - Wiring diagram, Section 8